

È [ d çæã È<sup>˘</sup>  
ÈÈ Ì ÁÈ Ì DÌ ÈÈÈÈ ÈÈ ÈÈ  
^È æÈÈÈ { O { [ d çæã È<sup>˘</sup>

ÚÜZÒSÝÖÞÖK PÖÈÈ ÈÈÈÈÓÍ

Υ ÖUSÁÖ



## ÖÖË ÒÁÒÔÏ ÒÏÏ ÒÁÏ ÏÏÏ

GR Size	A63
VERS Gear box version	T-With Feet
RAP Ratio	
PAM Input PAM flange	90 B5
ACU1 Output shaft (d*l)	40x80
DFU Output flange dimension (d)	-
TIP Motor/Inverter Motor	No
GRA Motor size	-
ALI Supply	-
GIRI Speed Range	-
POTE Power Group	-
CTRL Manual Adjustment Control	-
MODU Expansion modules	-
RAF Cooling	-
FC Motor execution	-
TF Break type	-
AF Brake power supply	-
COP Terminal box cover	-
CVE Fan cover	-
MOR Terminal box cover position	-
B	-
BB	-
BM	8
BM1	-
C	35
D Output shaft (d*l)	40
DM	24
DM1	-
E	110
EE	-
F	-

<b>F1</b>	<b>155.5</b>
<b>FF</b>	-
<b>FF1</b>	-
<b>G</b>	<b>227</b>
<b>G2</b>	<b>86</b>
<b>H</b>	<b>120</b>
<b>H1</b>	-
<b>I</b>	-
<b>II</b>	<b>135.5</b>
<b>K</b>	<b>20</b>
<b>L</b>	-
<b>M</b>	-
<b>M1</b>	<b>170</b>
<b>M2</b>	<b>185</b>
<b>N</b>	-
<b>NN</b>	<b>200</b>
<b>O</b>	<b>14</b>
<b>P</b>	-
<b>PM</b>	<b>200</b>
<b>PM1</b>	-
<b>Q</b>	<b>120</b>
<b>R</b>	<b>150</b>
<b>S</b>	<b>15</b>
<b>SS</b>	<b>20</b>
<b>T</b>	-
<b>TM</b>	<b>27.3</b>
<b>TM1</b>	-
<b>TT</b>	-
<b>V</b>	-
<b>W</b>	<b>218</b>
<b>X</b>	-
<b>Y</b>	-

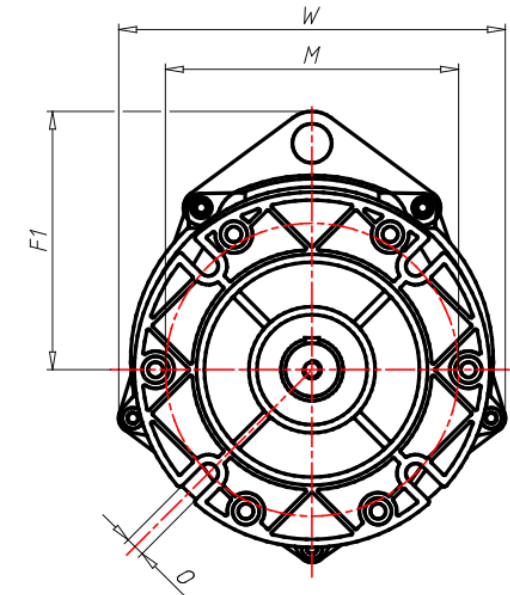
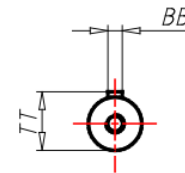
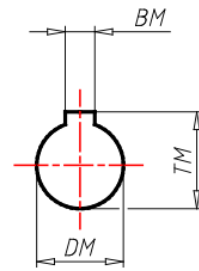
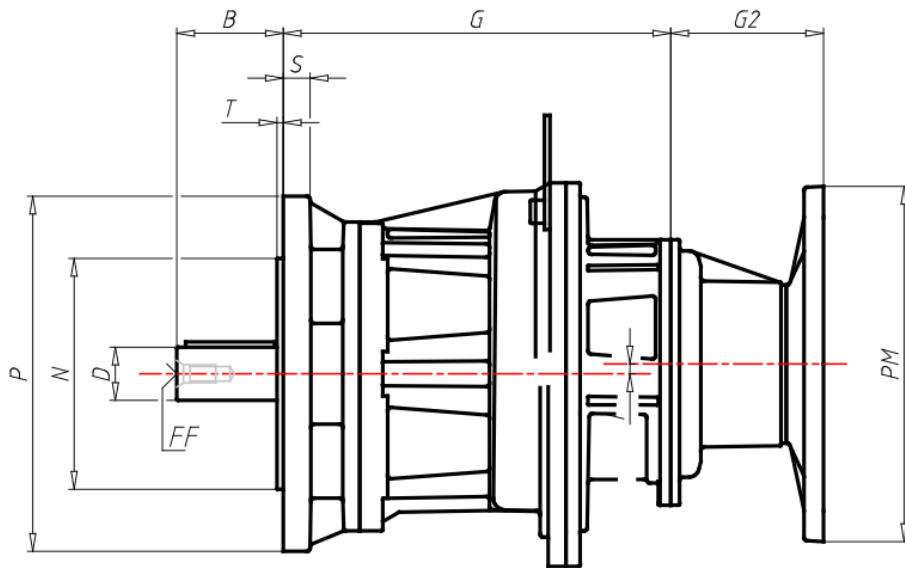
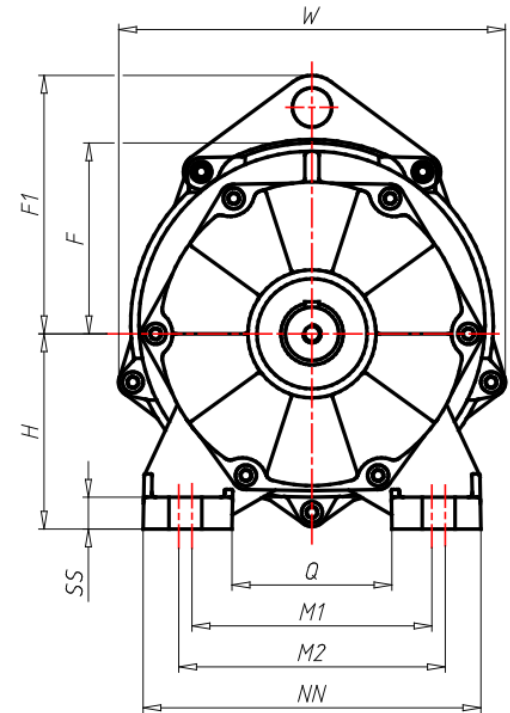
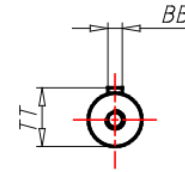
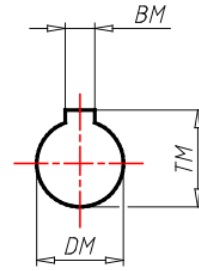
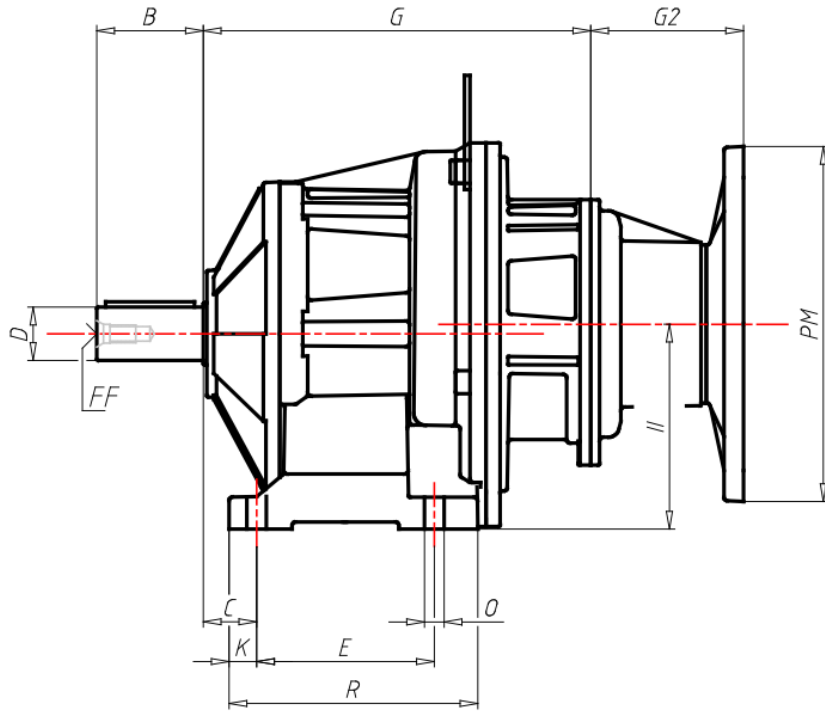

ΑΙΣΘΗΤΗΡΕΣ

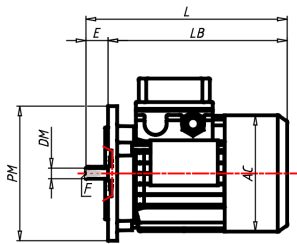

B5

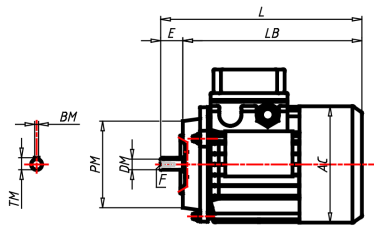

B14

