

È [d çæã È~
C' ÈÈ I ÀÈ I DNI HÈÈ I ÁÁ
^È æãÈ { O { [d çæã È~

ÚÜZÒSÝÖÞÖK PÖË HÈ €ÓÍ

Υ ÖUSÁÖ



ÖÖÈ ÒÁÒÔÈÈ ÒÁÒÁ ÿT ÖËÿ

GR Size	A63
VERS Gear box version	T-With Feet
RAP Ratio	
PAM Input PAM flange	80 B5
ACU1 Output shaft (d*l)	40x80
DFU Output flange dimension (d)	-
TIP Motor/Inverter Motor	No
GRA Motor size	-
ALI Supply	-
GIRI Speed Range	-
POTE Power Group	-
CTRL Manual Adjustment Control	-
MODU Expansion modules	-
RAF Cooling	-
FC Motor execution	-
TF Break type	-
AF Brake power supply	-
COP Terminal box cover	-
CVE Fan cover	-
MOR Terminal box cover position	-
B	-
BB	-
BM	6
BM1	-
C	35
D Output shaft (d*l)	40
DM	19
DM1	-
E	110
EE	-
F	-

F1	155.5
FF	-
FF1	-
G	227
G2	86
H	120
H1	-
I	-
II	135.5
K	20
L	-
M	-
M1	170
M2	185
N	-
NN	200
O	14
P	-
PM	200
PM1	-
Q	120
R	150
S	15
SS	20
T	-
TM	21.8
TM1	-
TT	-
V	-
W	218
X	-
Y	-

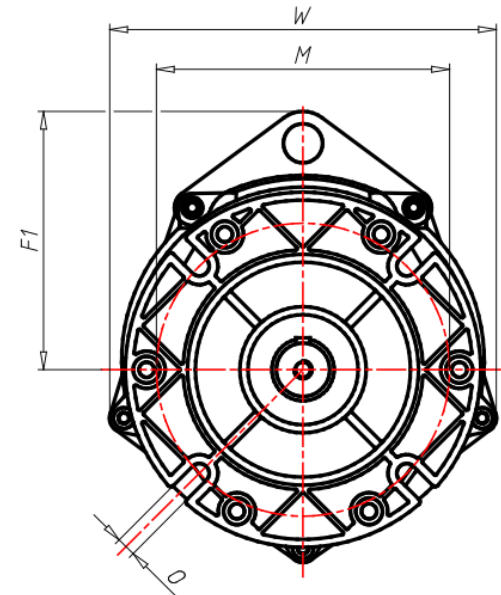
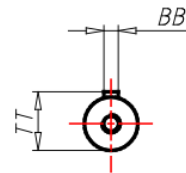
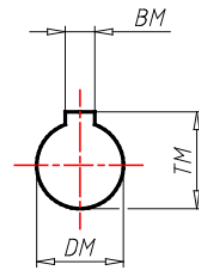
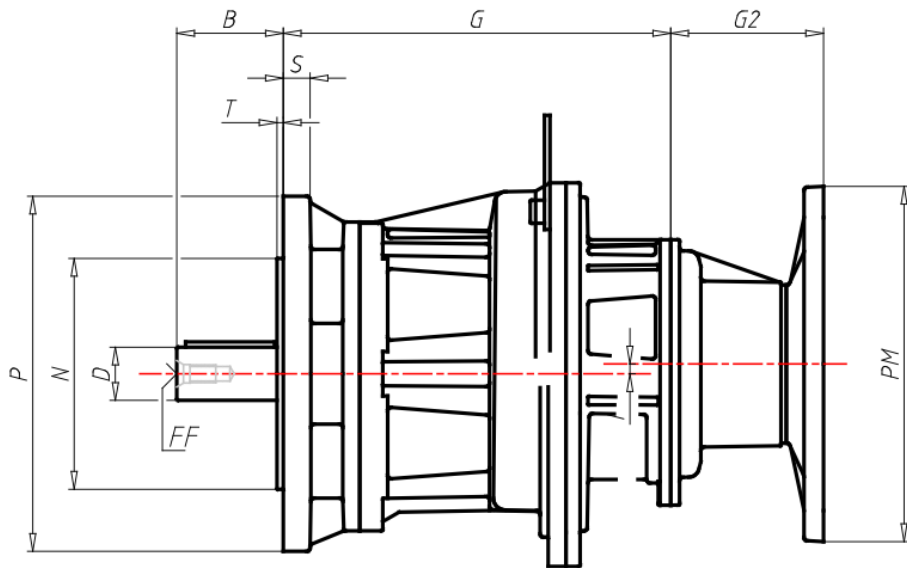
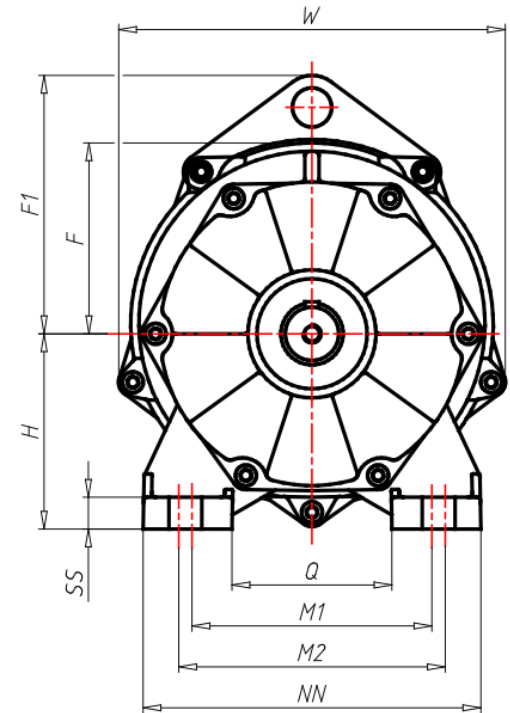
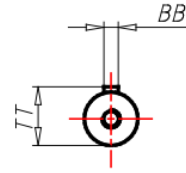
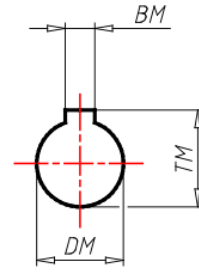
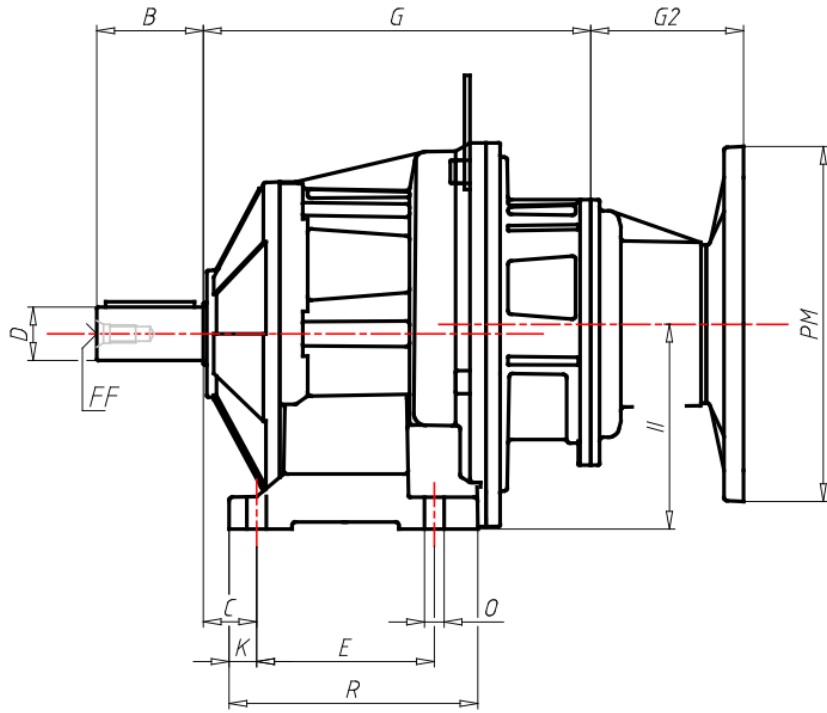

ΑΙΣΘΗΤΗΡΕΣ

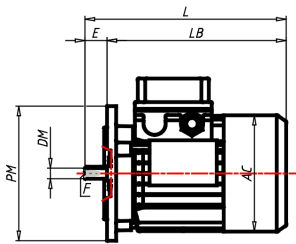

B5

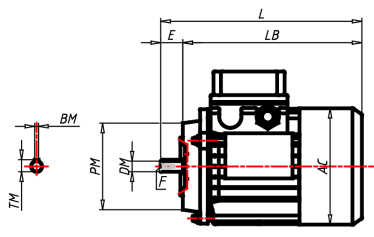

B14

