

È [d çæã È[~]
ÈÈ | ÀÈ | DÀ | HÈÈÈ | ÁÁ
^È æã { O { [d çæã È[~]

ÚÜZÒSÝÖÖÞÖK ÓËÏ HËGGÍ ÓÍ

Y ÖUSÁÖ

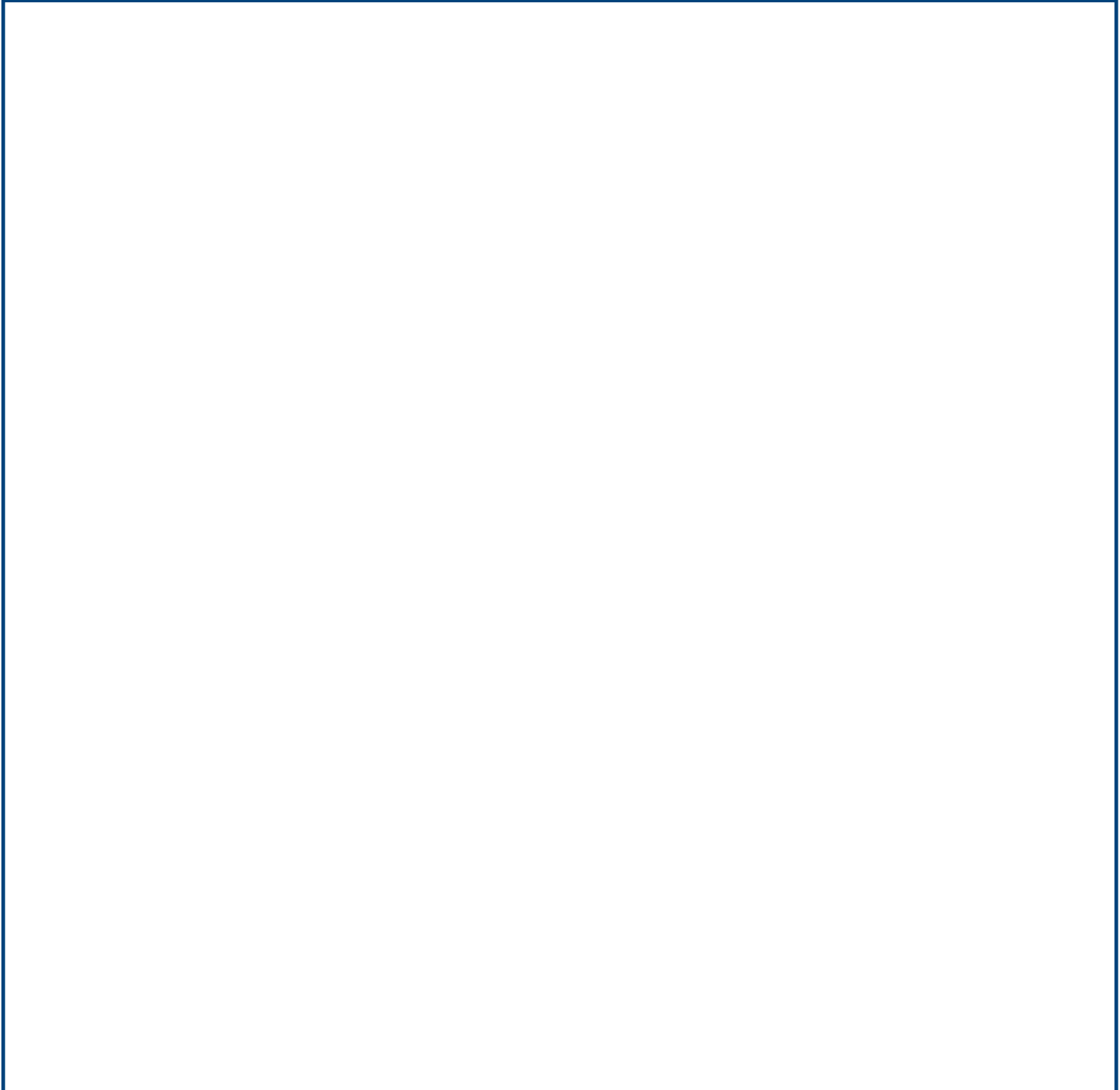

ÖÖË ÒÁÒÔÏ ÒÏÏ ÒÁÏ ÏÏÏ

GR Size	163
VERS Gear box version	U-Universal
VERSALBE Output shaft version	C-Hollow
RAP Ratio	
PAM Input PAM flange	225 B5
ACU1 Output shaft (d*l)	100
TFU Output flange	NO
DFU Output flange dimension (d)	-
PFU Output flange position	-
AL Low speed shaft accessory (d)	No
PAL Low speed shaft accessory position	-
BR Torque arm	No
PBR Torque arm position	-
CP Protection cover position	NO
TIP Motor/Inverter Motor	No
GRA Motor size	-
RAF Cooling	-
FC Motor execution	-
ALI Supply	-
GIRI Speed Range	-
POTE Power Group	-
CTRL Manual Adjustment Control	-
MODU Expansion modules	-
TF Break type	-
AF Brake power supply	-
RF Brake rectifier	-
ACC Accessories	-
COP Terminal box cover	-
SER Forced ventilation	-
CVE Fan cover	-
MOR Terminal box cover position	-

A	146
B	-
BB	-
BB1	28
BM	18
BM1	-
C	-
C1	155
D	-
D1	100
DM	60
DM1	-
E	-
EE	-
E1	420
F	615
F1	-
FF	-
FF1	-
G	426.5
G1	445
H	375
H1	-
I	47
K	230.5
K1	-
LL	-
M	330
N	400
O	38
PM	450

PM1	-
S	45
TT	-
TT1	106.4
TM	64.4
TM1	-
U	40
V	100
X	-
Y	-

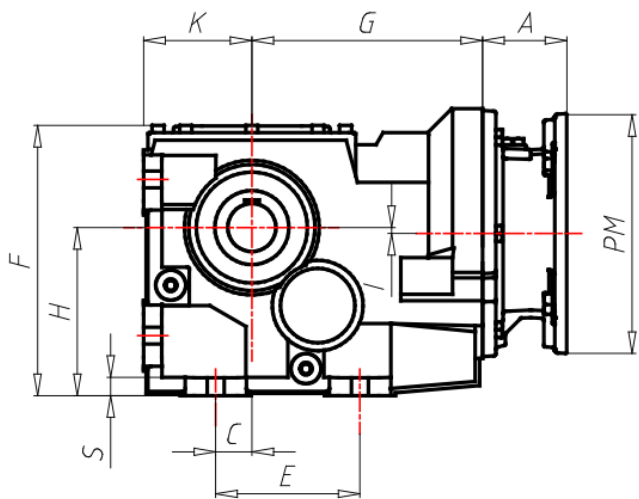

B/PB...F

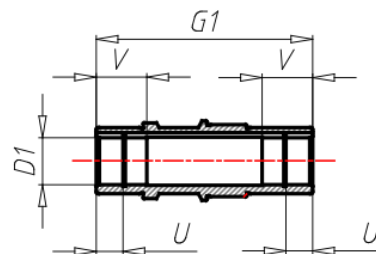
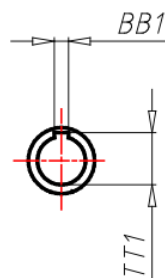
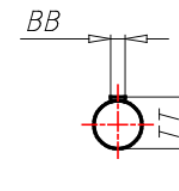
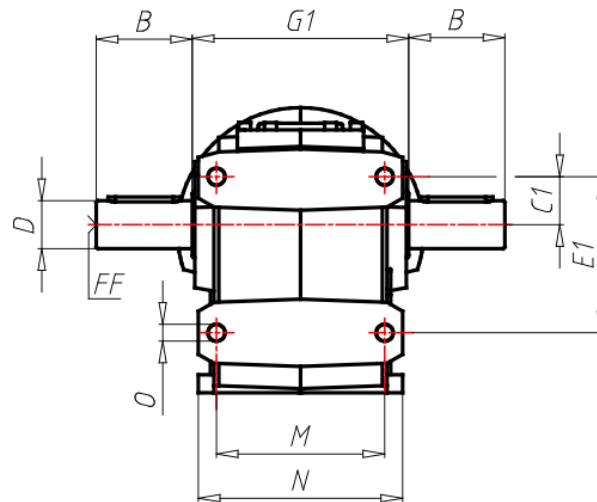
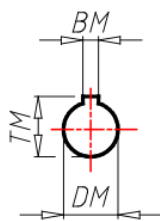

B/PB...S

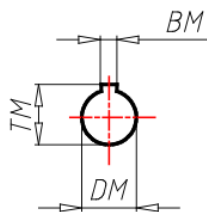

B/PB...U

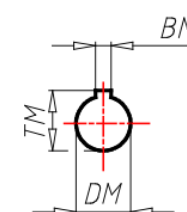

ΑΕΣΟΪΟΥ ΪΘΕ

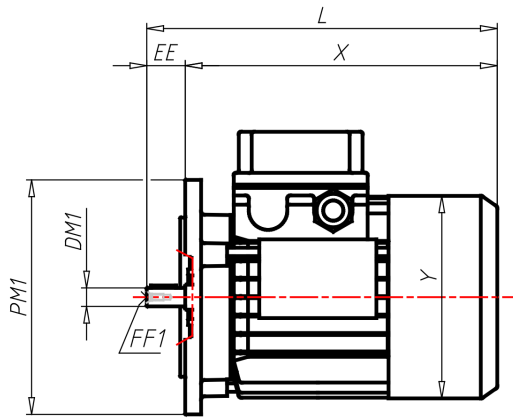

B5

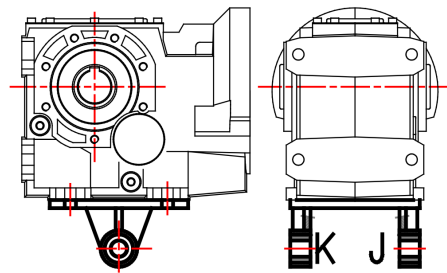
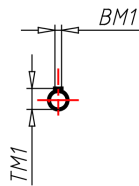

143-153-163

