

È [ q çæã È^  
è | ÈÈ | ÁÈ | DÌ | HÈÈÈ | ÁÁ  
^È æ | Å | O | [ q çæã È^

ÚÜZÒSÝÖPØK ÓËÈÈÈÓÍ

Υ ÖUSÁÖ



## ÖÖË ÒÁÒÔÏ ÒÛÏ ÒÁÏ ÿÏ ÖÛÿ

<b>GR Size</b>	143
<b>VERS Gear box version</b>	U-Universal
<b>VERSALBE Output shaft version</b>	C-Hollow
<b>RAP Ratio</b>	
<b>PAM Input PAM flange</b>	200 B5
<b>ACU1 Output shaft (d*l)</b>	70
<b>TFU Output flange</b>	NO
<b>DFU Output flange dimension (d)</b>	-
<b>PFU Output flange position</b>	-
<b>AL Low speed shaft accessory (d)</b>	No
<b>PAL Low speed shaft accessory position</b>	-
<b>BR Torque arm</b>	No
<b>PBR Torque arm position</b>	-
<b>CP Protection cover position</b>	NO
<b>TIP Motor/Inverter Motor</b>	No
<b>GRA Motor size</b>	-
<b>RAF Cooling</b>	-
<b>FC Motor execution</b>	-
<b>ALI Supply</b>	-
<b>GIRI Speed Range</b>	-
<b>POTE Power Group</b>	-
<b>CTRL Manual Adjustment Control</b>	-
<b>MODU Expansion modules</b>	-
<b>TF Break type</b>	-
<b>AF Brake power supply</b>	-
<b>RF Brake rectifier</b>	-
<b>ACC Accessories</b>	-
<b>COP Terminal box cover</b>	-
<b>SER Forced ventilation</b>	-
<b>CVE Fan cover</b>	-
<b>MOR Terminal box cover position</b>	-

<b>A</b>	<b>185</b>
<b>B</b>	<b>-</b>
<b>BB</b>	<b>-</b>
<b>BB1</b>	<b>20</b>
<b>BM</b>	<b>16</b>
<b>BM1</b>	<b>-</b>
<b>C</b>	<b>-</b>
<b>C1</b>	<b>90</b>
<b>D</b>	<b>-</b>
<b>D1</b>	<b>70</b>
<b>DM</b>	<b>55</b>
<b>DM1</b>	<b>-</b>
<b>E</b>	<b>-</b>
<b>EE</b>	<b>-</b>
<b>E1</b>	<b>280</b>
<b>F</b>	<b>414</b>
<b>F1</b>	<b>-</b>
<b>FF</b>	<b>-</b>
<b>FF1</b>	<b>-</b>
<b>G</b>	<b>279</b>
<b>G1</b>	<b>300</b>
<b>H</b>	<b>265</b>
<b>H1</b>	<b>-</b>
<b>I</b>	<b>34</b>
<b>K</b>	<b>160</b>
<b>K1</b>	<b>-</b>
<b>LL</b>	<b>-</b>
<b>M</b>	<b>240</b>
<b>N</b>	<b>290</b>
<b>O</b>	<b>22</b>
<b>PM</b>	<b>400</b>

<b>PM1</b>	-
<b>S</b>	<b>22</b>
<b>TT</b>	-
<b>TT1</b>	<b>74.9</b>
<b>TM</b>	<b>59.3</b>
<b>TM1</b>	-
<b>U</b>	<b>27.5</b>
<b>V</b>	<b>75</b>
<b>X</b>	-
<b>Y</b>	-

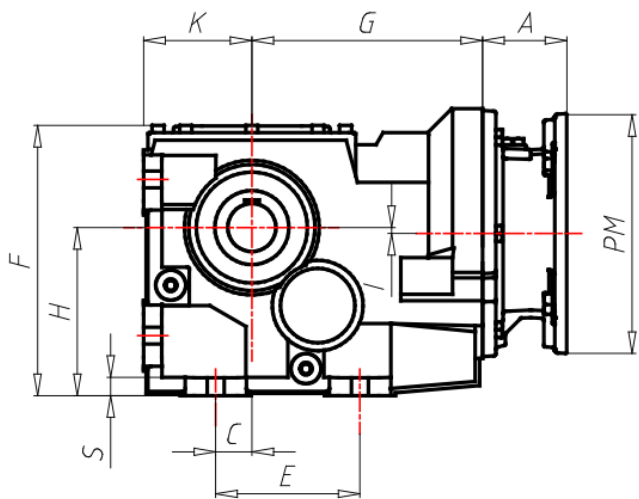

B/PB...F

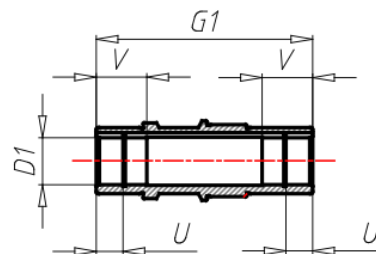
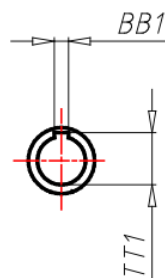
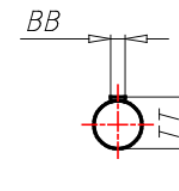
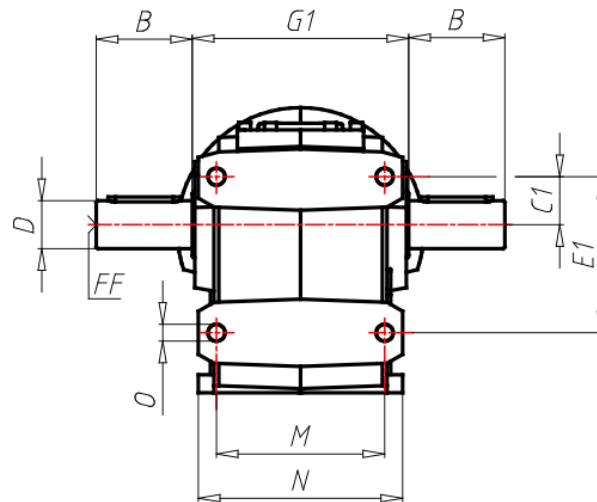
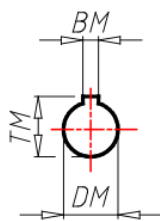

B/PB...S

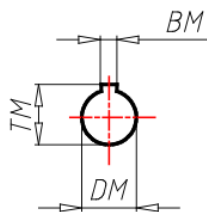

B/PB...U

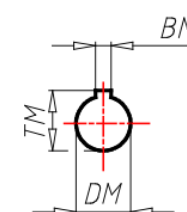

ΑΕΣΟΪΟΥ ΪΘΕ

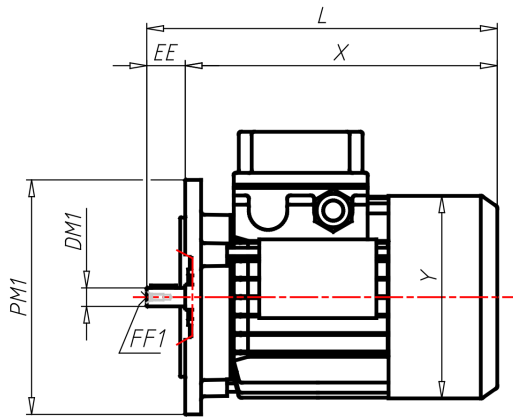

B5

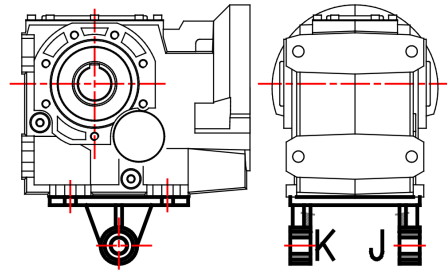
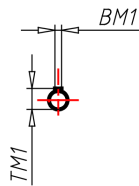

143-153-163

