

ÖÖË ÒÁÒÔÏ ÒÛÏ ÒÁÏ ÿÏ ÖÛÿ

GR Size	143
VERS Gear box version	U-Universal
VERSALBE Output shaft version	C-Hollow
RAP Ratio	
PAM Input PAM flange	132 B5
ACU1 Output shaft (d*l)	70
TFU Output flange	NO
DFU Output flange dimension (d)	-
PFU Output flange position	-
AL Low speed shaft accessory (d)	No
PAL Low speed shaft accessory position	-
BR Torque arm	No
PBR Torque arm position	-
CP Protection cover position	NO
TIP Motor/Inverter Motor	No
GRA Motor size	-
RAF Cooling	-
FC Motor execution	-
ALI Supply	-
GIRI Speed Range	-
POTE Power Group	-
CTRL Manual Adjustment Control	-
MODU Expansion modules	-
TF Break type	-
AF Brake power supply	-
RF Brake rectifier	-
ACC Accessories	-
COP Terminal box cover	-
SER Forced ventilation	-
CVE Fan cover	-
MOR Terminal box cover position	-

A	101
B	-
BB	-
BB1	20
BM	10
BM1	-
C	-
C1	90
D	-
D1	70
DM	38
DM1	-
E	-
EE	-
E1	280
F	414
F1	-
FF	-
FF1	-
G	279
G1	300
H	265
H1	-
I	34
K	160
K1	-
LL	-
M	240
N	290
O	22
PM	300

PM1	-
S	22
TT	-
TT1	74.9
TM	41.3
TM1	-
U	27.5
V	75
X	-
Y	-

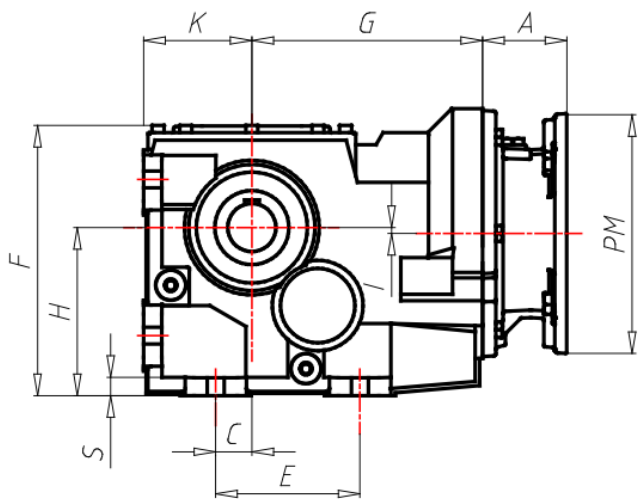

B/PB...F

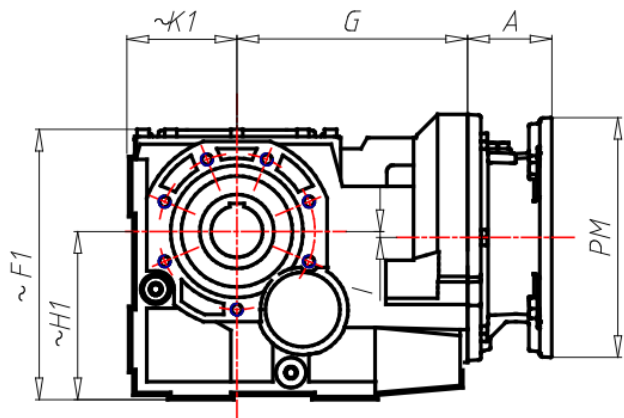
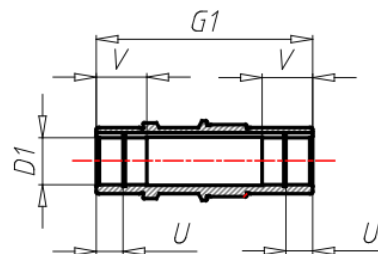
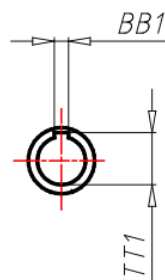
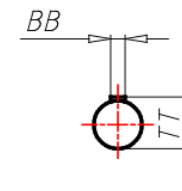
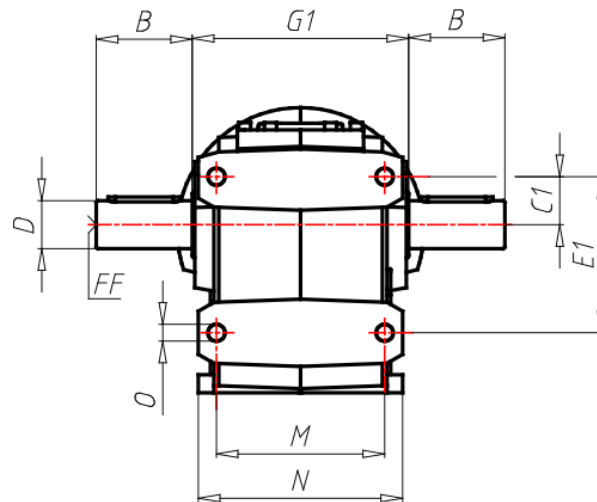
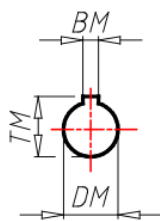

B/PB...S

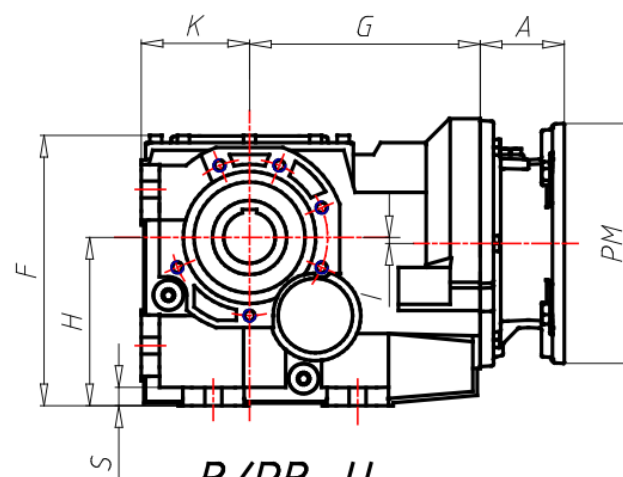
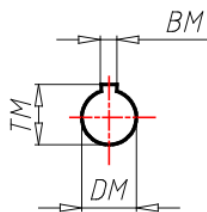

B/PB...U

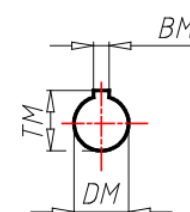

ΑΕΣΟΪΟΥ ΪΘΕ

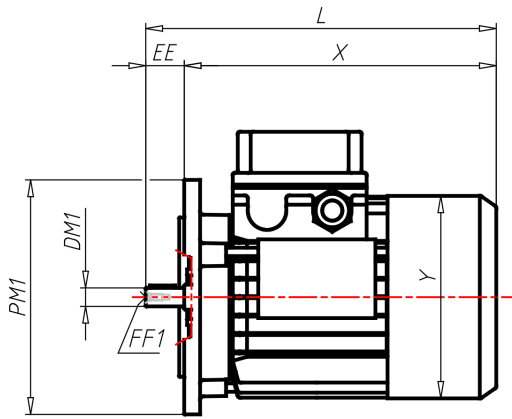

B5

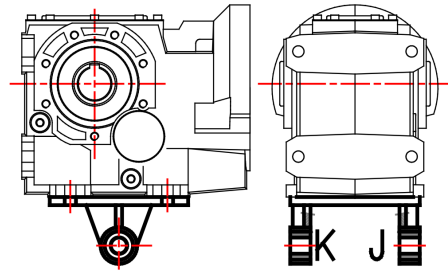
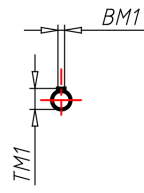

143-153-163

