

È [d çæã È[˘]
è | ÈÈ | ÁÈ | DÌ | HÈÈ | Á
^È æã { O { [d çæã È[˘]

ÚÜZÒSýÖÖÞÖK ÓÈÈGHÈÈÈÈÈFGÓÍ

Y ÖUSÁÖ

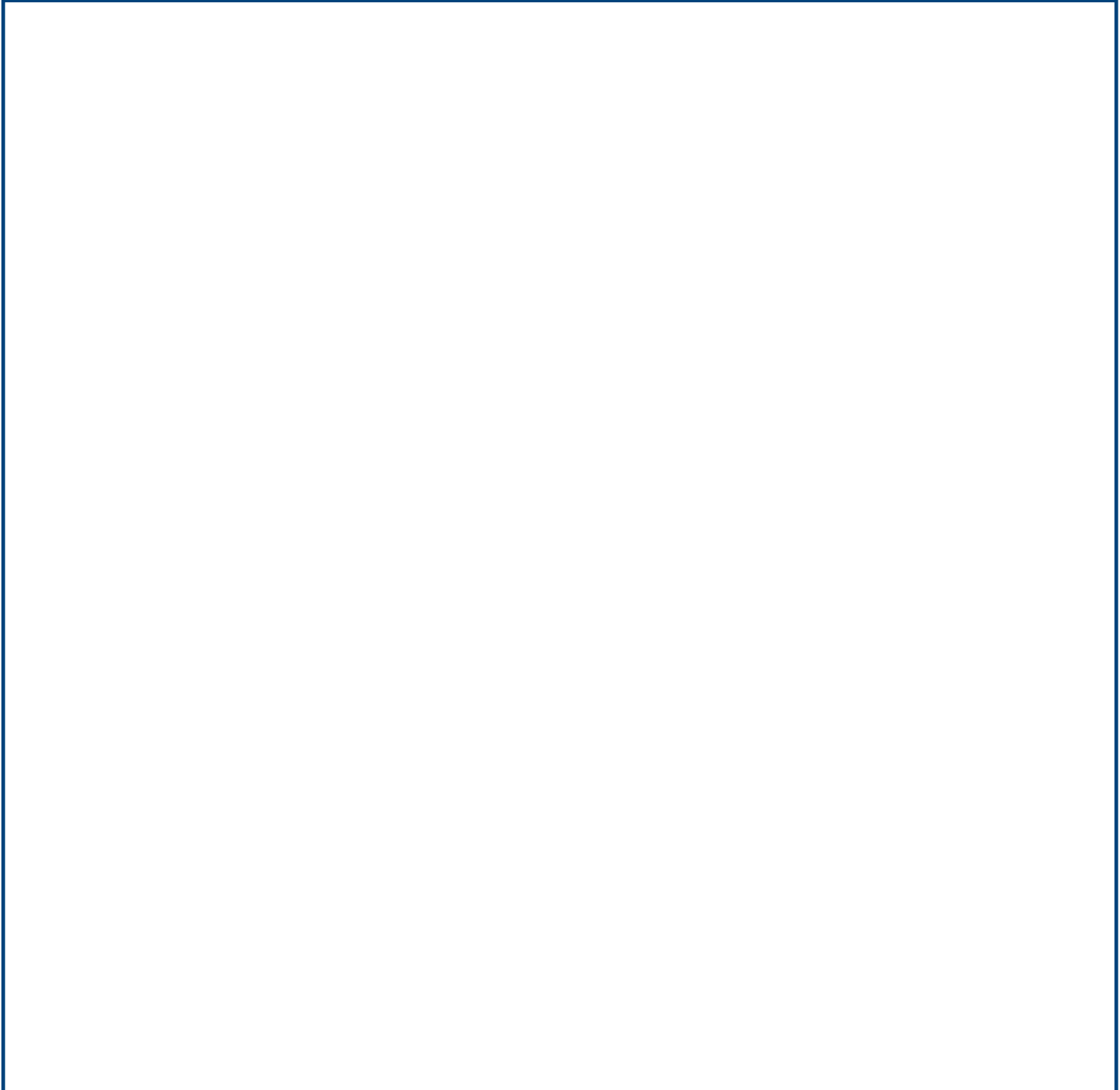

ÖÖË ÒÁÒÔÏ ÒÛÏ ÒÁÏ ÿÏ Öÿ

GR Size	123
VERS Gear box version	U-Universal
VERSALBE Output shaft version	C-Hollow
RAP Ratio	
PAM Input PAM flange	100-112 B5
ACU1 Output shaft (d*l)	60
TFU Output flange	NO
DFU Output flange dimension (d)	-
PFU Output flange position	-
AL Low speed shaft accessory (d)	No
PAL Low speed shaft accessory position	-
BR Torque arm	No
PBR Torque arm position	-
CP Protection cover position	NO
TIP Motor/Inverter Motor	No
GRA Motor size	-
RAF Cooling	-
FC Motor execution	-
ALI Supply	-
GIRI Speed Range	-
POTE Power Group	-
CTRL Manual Adjustment Control	-
MODU Expansion modules	-
TF Break type	-
AF Brake power supply	-
RF Brake rectifier	-
ACC Accessories	-
COP Terminal box cover	-
SER Forced ventilation	-
CVE Fan cover	-
MOR Terminal box cover position	-

A	76
B	-
BB	-
BB1	18
BM	8
BM1	-
C	-
C1	78
D	-
D1	60
DM	28
DM1	-
E	-
EE	-
E1	220
F	341
F1	-
FF	-
FF1	-
G	246
G1	240
H	212
H1	-
I	33.5
K	132
K1	-
LL	-
M	180
N	230
O	22
PM	250

PM1	-
S	22
TT	-
TT1	64.4
TM	31.3
TM1	-
U	28
V	70
X	-
Y	-

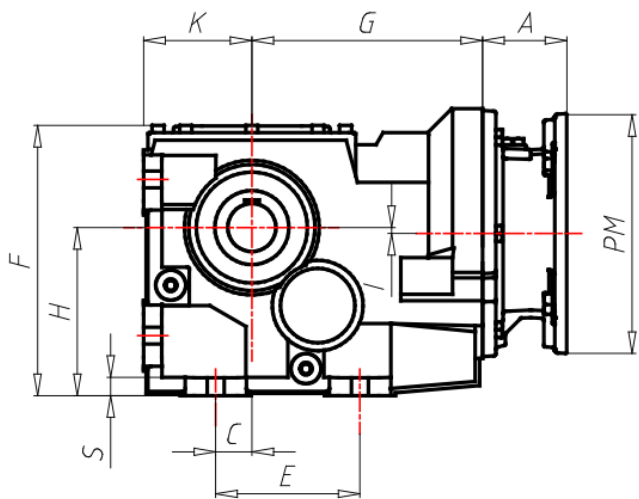

B/PB...F

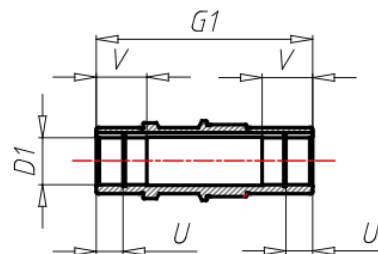
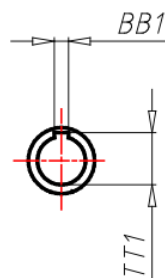
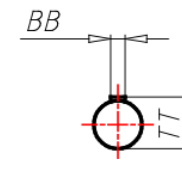
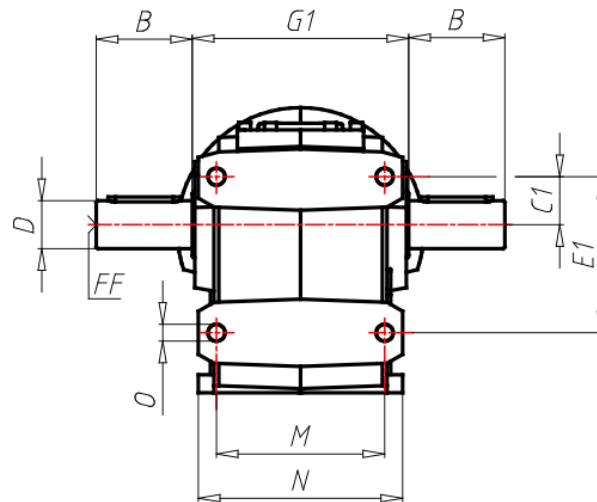
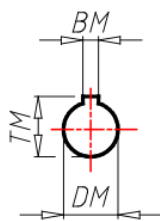

B/PB...S

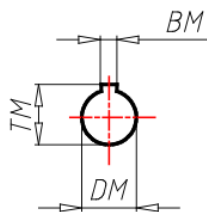

B/PB...U

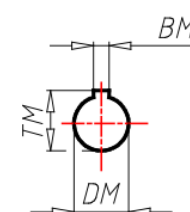

ΑΕΣΟΪΟΥ ΪΘΕ

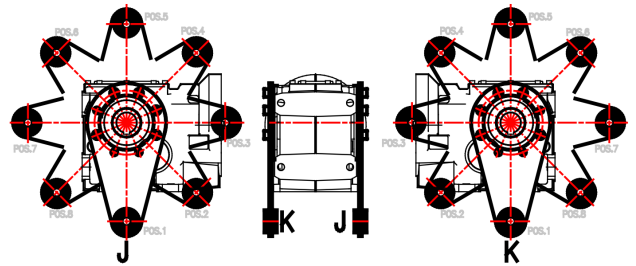
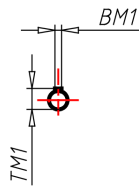
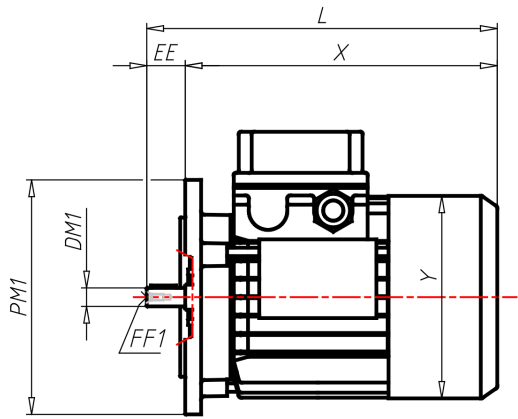

B5

