

È [d çæã È~
è | ÈÈ | ÀÈ | DÌ | HÈÈ | Á
^È æá { O { [d çæã È~

ÚÜZÒSýÖÞÖK ÓË€HËÎ €ÓÍ

Υ ÖUSÁÖ



ÖÖË ÒÁ/ÒÔP ÒÛZ ÒÁ/ÒÔS ÔÒÙU ÜÖË

GR Size	103
VERS Gear box version	U-Universal
VERSALBE Output shaft version	C-Hollow
RAP Ratio	
PAM Input PAM flange	160 B5
ACU1 Output shaft (d*l)	50
TFU Output flange	NO
DFU Output flange dimension (d)	-
PFU Output flange position	-
AL Low speed shaft accessory (d)	No
PAL Low speed shaft accessory position	-
BR Torque arm	No
PBR Torque arm position	-
CP Protection cover position	NO
TIP Motor/Inverter Motor	No
GRA Motor size	-
RAF Cooling	-
FC Motor execution	-
ALI Supply	-
GIRI Speed Range	-
POTE Power Group	-
CTRL Manual Adjustment Control	-
MODU Expansion modules	-
TF Break type	-
AF Brake power supply	-
RF Brake rectifier	-
ACC Accessories	-
COP Terminal box cover	-
SER Forced ventilation	-
CVE Fan cover	-
MOR Terminal box cover position	-

A	158
B	-
BB	-
BB1	14
BM	12
BM1	-
C	-
C1	50
D	-
D1	50
DM	42
DM1	-
E	-
EE	-
E1	160
F	283
F1	-
FF	-
FF1	-
G	213.5
G1	210
H	180
H1	-
I	25
K	112
K1	-
LL	-
M	165
N	205
O	18
PM	350

PM1	-
S	18
TT	-
TT1	53.8
TM	45.3
TM1	-
U	25
V	50
X	-
Y	-

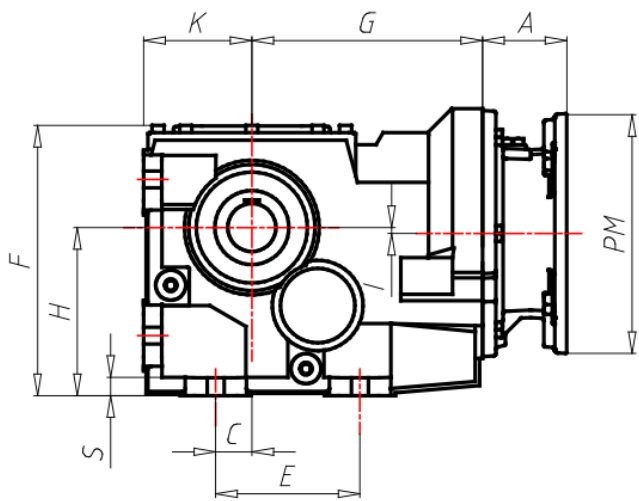

B/PB...F

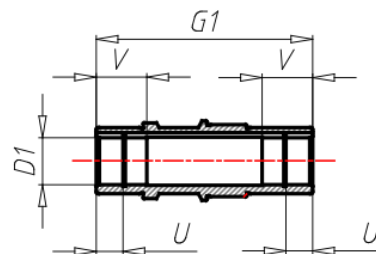
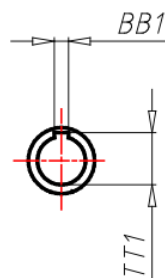
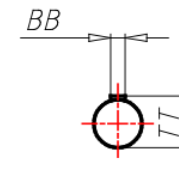
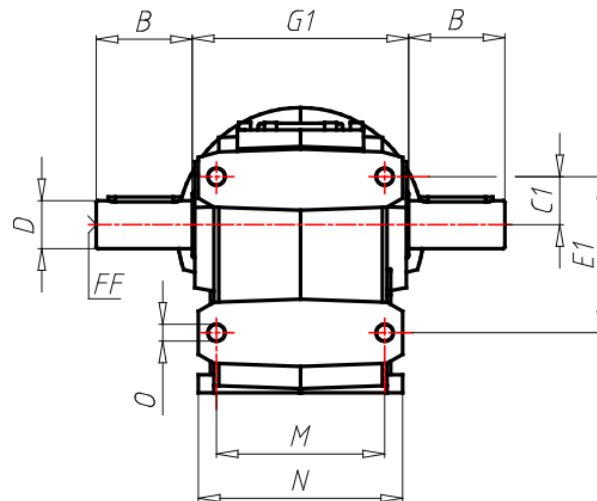
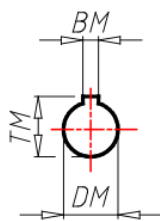

B/PB...S

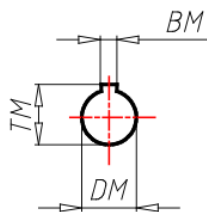

B/PB...U

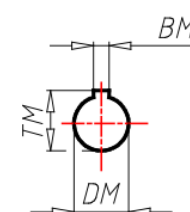

ΑΕΣΟΔΟΥΣ

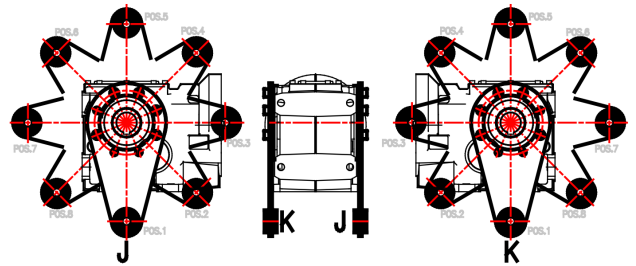
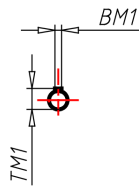
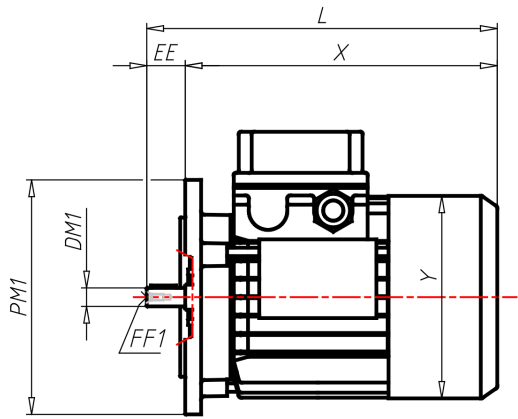

B5

