

È [d çæã È[˘]
ÈÈ | ÀÈ | ÀÈ | DÀÈ | ÈÈÈÈ | ÀÈ
^È æãÈ { O { [d çæã È[˘]

ÚÛZÒSýÖÞØK PÈÈÈÈÈÓÍ

Y ÖUSÁÖ

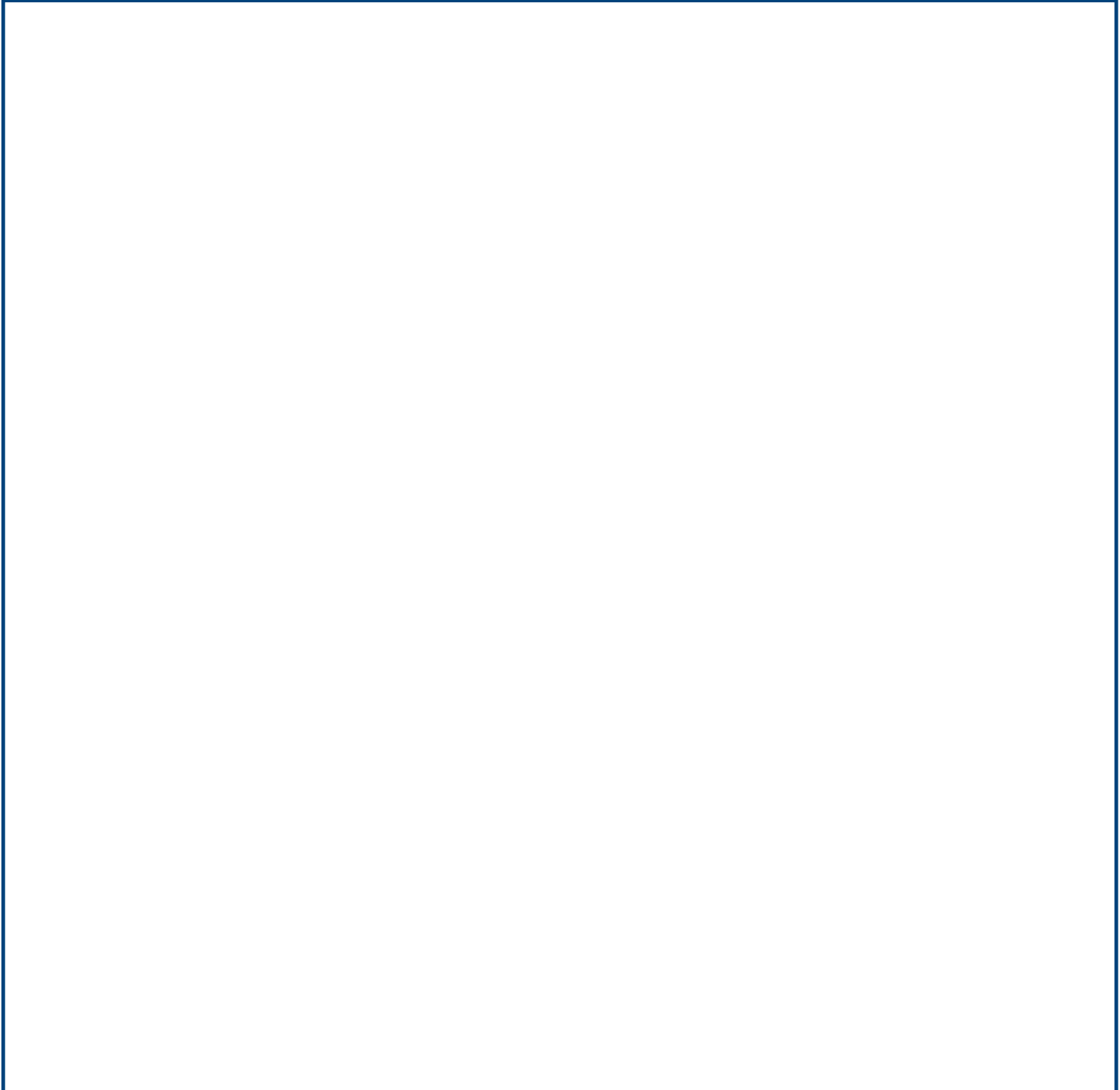

ÖÖË ÒÁÒÔÏ ÒÏÏ ÒÁÏ ÏÏÏ

GR Size	103
VERS Gear box version	T-With Feet
RAP Ratio	
PAM Input PAM flange	90 B5
ACU1 Output shaft (d*I)	60x120
TFU Output flange	-
DFU Output flange dimension (d)	-
TIP Motor/Inverter Motor	No
GRA Motor size	-
ALI Supply	-
GIRI Speed Range	-
POTE Power Group	-
CTRL Manual Adjustment Control	-
MODU Expansion modules	-
RAF Cooling	-
FC Motor execution	-
TF Break type	-
AF Brake power supply	-
COP Terminal box cover	-
CVE Fan cover	-
MOR Terminal box cover position	-
A	61
B	120
BB	18
BM	8
BM1	-
C	40
D Output shaft (d*I)	60
DM	24
DM1	-
E	310

EE	-
F	364
FF	M20
FF1	-
G	316
G1	-
H	225
I	35.5
K	27.5
L	-
M	250
N	330
O	22
PM	200
PM1	-
Q	166
R	365
S	30
TM	27.3
TM1	-
TT	64
X	-
Y	-

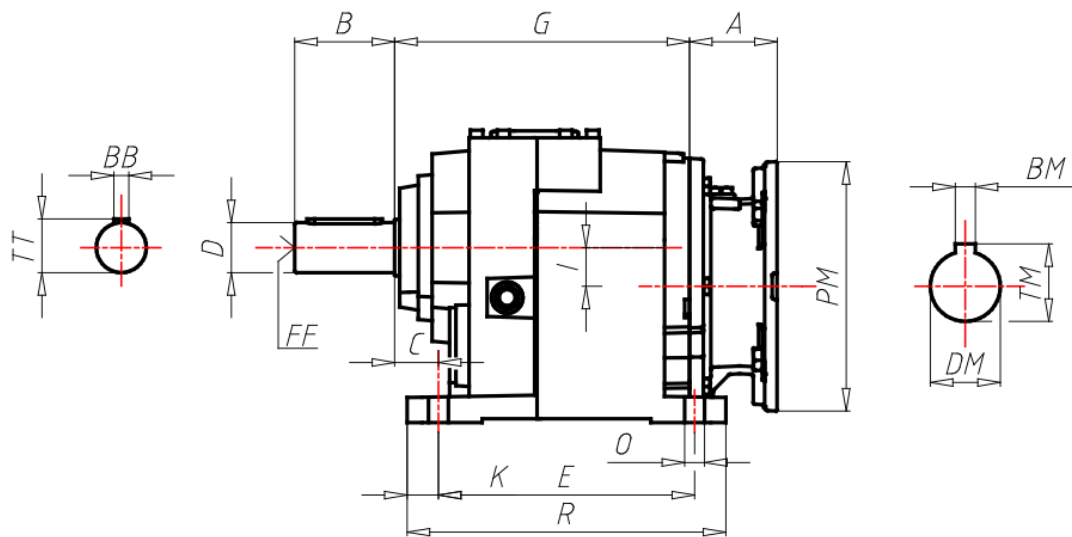

H/PH...T

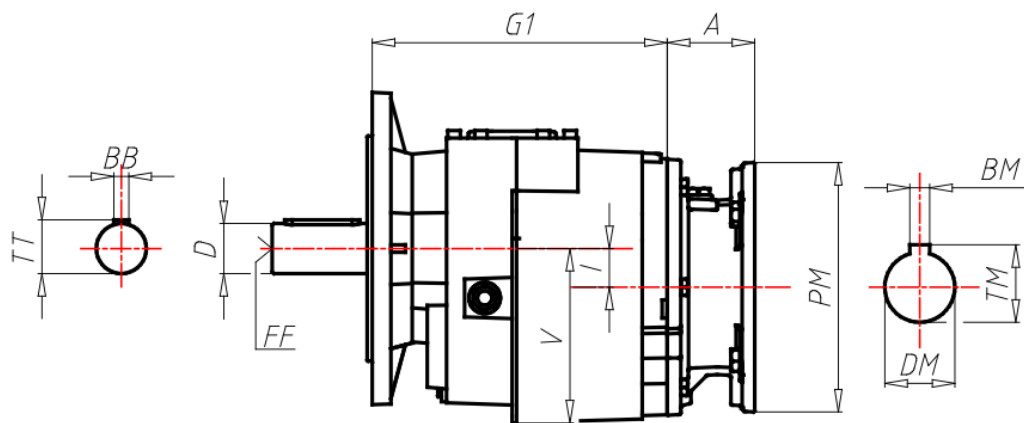
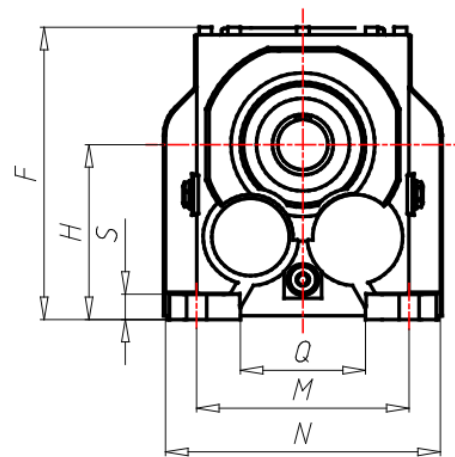

H/PH...F

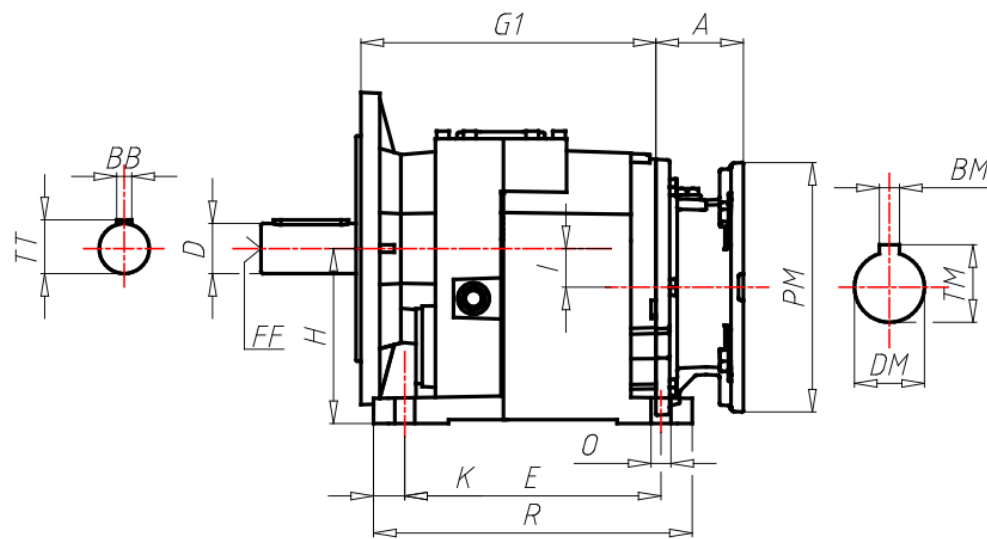

H/PH...U

ΑΞΟΝΟΔΕΞΗ

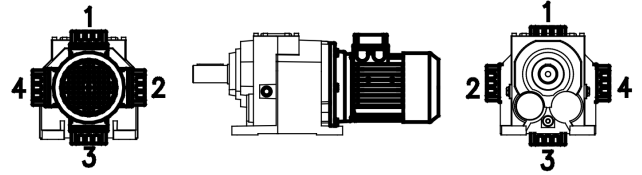
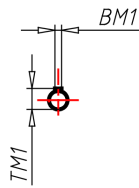
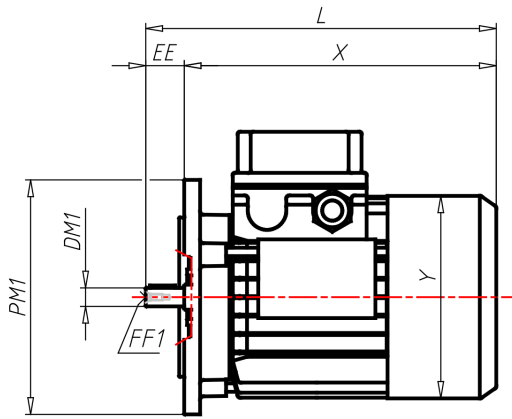

B5