



ÖÖË ÒÁ/ÒÔÏ ÒÛÏ

GR Size	090
RAP Ratio	ì éí òá/òôí òá/òôí òá/òôí òá/òôí òá/òôí òá/òôí
PAM Input PAM flange	90 B5
ACU Output hole shaft (d)	35
VB Double input shaft	NO
TFU Output flange	T
DFU Output flange dimension (d)	-
PFU Output flange position	-
AL Output hole shaft (d)	No
PAL Output shaft position	-
BR Torque arm	No
PBR Pos. torque arm	-
CAP Cover	No
TIP Motor/Inverter Motor	No
GRA Motor size	-
ALI Supply	-
GIRI Speed Range	-
POTE Power Group	-
CTRL Manual Adjustment Control	-
MODU Expansion modules	-
RAF Cooling	-
FC Motor execution	-
TF Break type	-
AF Brake power supply	-
COP Terminal box cover	-
CVE Fan cover	-
MOR Pos. terminal box	-
A	-
AC	-
A1	-
B	50

ÖÖË ÒÁ/ÒÔÏ ÒÏË

BB	10
BM	8
BM1	-
B1	8
C	-
D	35
D1	24
DM	24
DM1	-
E	-
EA	-
EB	-
EC	-
F	-
FF	M8
F1	-
GG	129.5
G1	-
G3	108
H	-
H1	97
H2	-
I	90
K	-
KE	M10x18
K0	-
K1	-
L	-
L1	-
LB	-
LL	-

## ÖÖË ÒÁÒÔÏ ÒÏË

<b>M</b>	<b>130</b>	
<b>N</b>	<b>110</b>	
<b>N1</b>	<b>67</b>	
<b>O</b>	<b>-</b>	
<b>P</b>	<b>148</b>	
<b>PM</b>	<b>200</b>	
<b>PM1</b>	<b>-</b>	
<b>Q</b>	<b>-</b>	
<b>R</b>	<b>133</b>	
<b>R1</b>	<b>-</b>	
<b>S</b>	<b>-</b>	
<b>S1</b>	<b>-</b>	
<b>T</b>	<b>45</b>	
<b>TM</b>	<b>27.3</b>	
<b>TM1</b>	<b>-</b>	
<b>TT</b>	<b>38.3</b>	
<b>TT1</b>	<b>27</b>	
<b>V</b>	<b>-</b>	
<b>W</b>	<b>45°</b>	

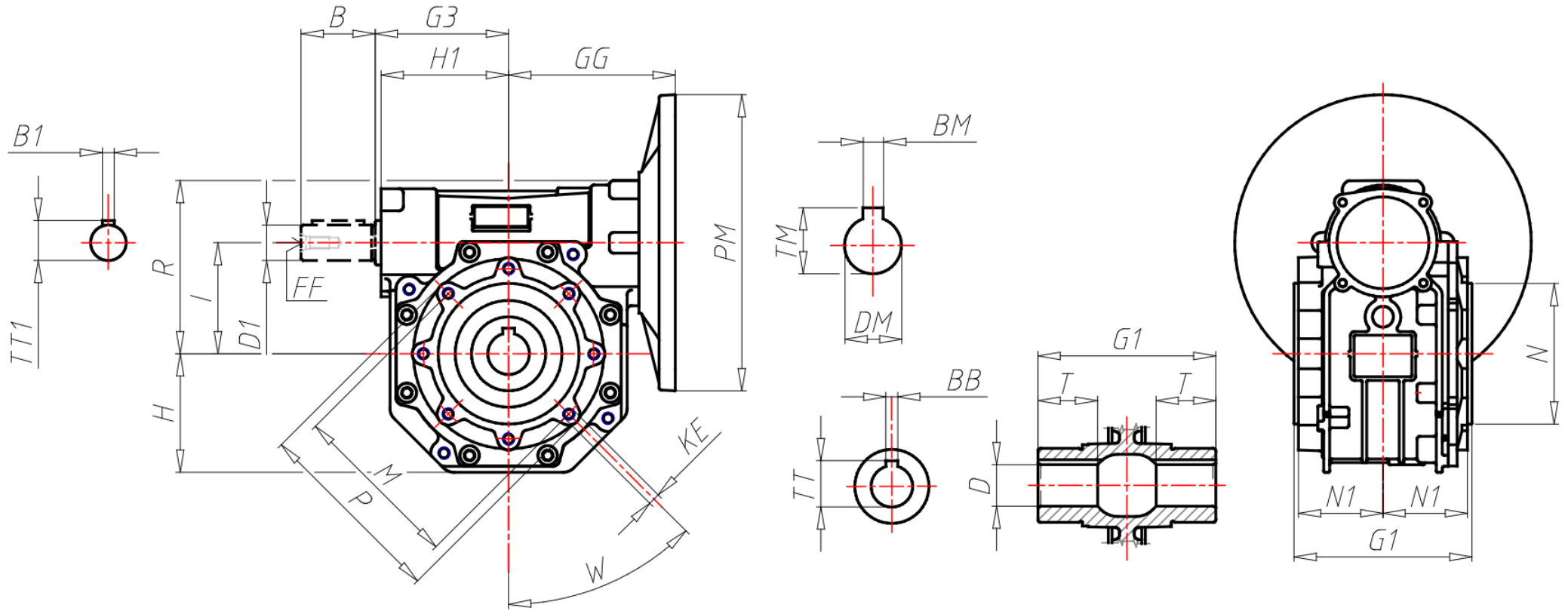

αεσôòùüœ

