

È [d çæã È~
À ÈÈ Ì ÁÈ Ì DÌ HÈ FÈ Ì ÁÈ æãã { O { [d çæã È~

ÚÜZÒSýÖÖÞÖK ÙY ÈÈ Í ÈÈÓÍ

Y ÖÖUSÁÖ

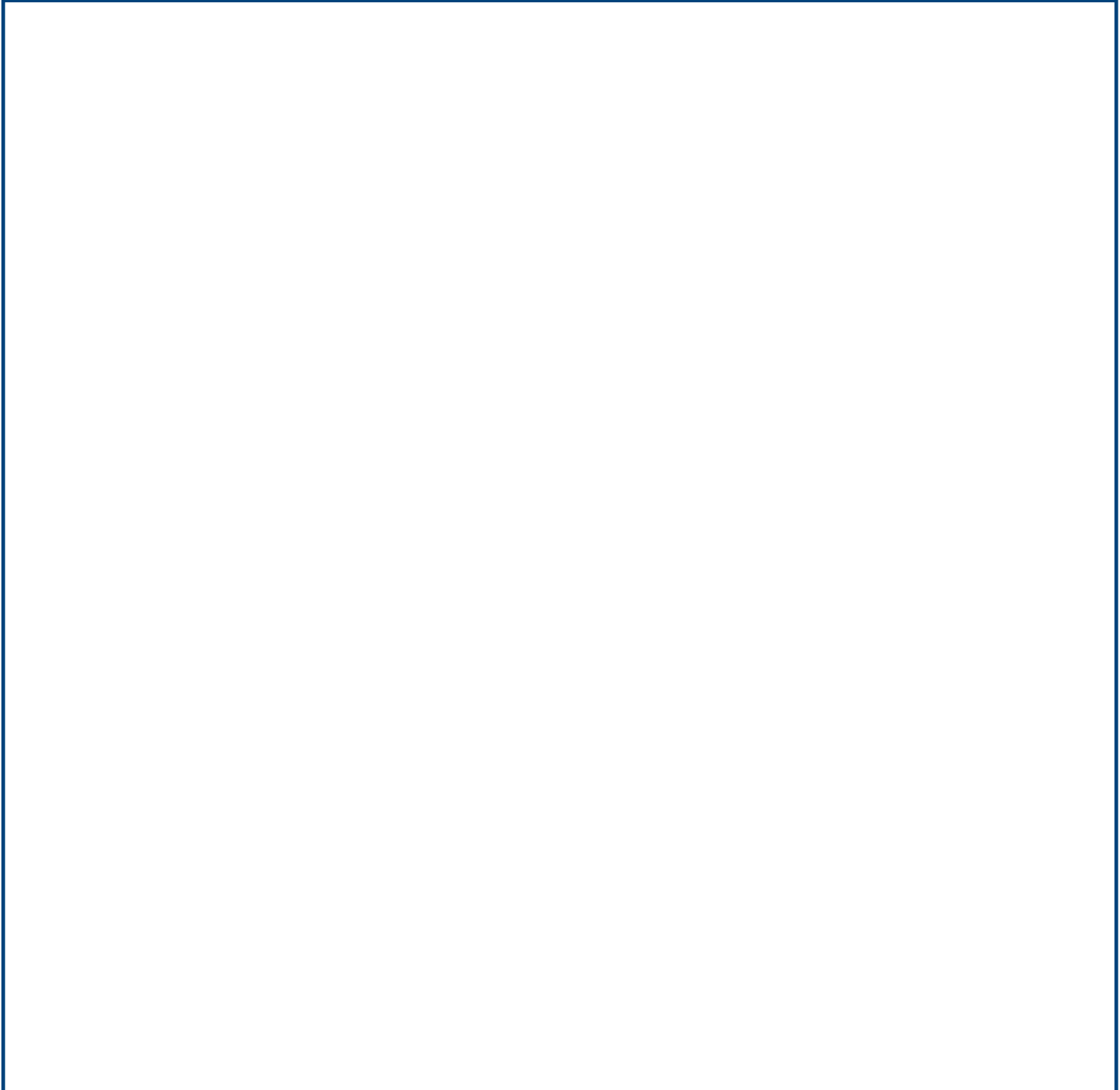

ÖÖË ÒÁ/ÒÔÏ ÒÏË

| | |
|---------------------------------|-------------------------------|
| GR Size | 075 |
| RAP Ratio | Ï È LÁ-ELÁÍ LÁGELÁÍ LÁHELÁ EL |
| PAM Input PAM flange | 90 B5 |
| ACU Output hole shaft (d) | 28 |
| VB Double input shaft | NO |
| TFU Output flange | T |
| DFU Output flange dimension (d) | - |
| PFU Output flange position | - |
| AL Output hole shaft (d) | No |
| PAL Output shaft position | - |
| BR Torque arm | No |
| PBR Pos. torque arm | - |
| CAP Cover | No |
| TIP Motor/Inverter Motor | No |
| GRA Motor size | - |
| ALI Supply | - |
| GIRI Speed Range | - |
| POTE Power Group | - |
| CTRL Manual Adjustment Control | - |
| MODU Expansion modules | - |
| RAF Cooling | - |
| FC Motor execution | - |
| TF Break type | - |
| AF Brake power supply | - |
| COP Terminal box cover | - |
| CVE Fan cover | - |
| MOR Pos. terminal box | - |
| A | - |
| AC | - |
| A1 | - |
| B | 50 |

ÖÖË ÒÁ/ÒÔÏ ÒÏË

| | |
|-----|-------|
| BB | 8 |
| BM | 8 |
| BM1 | - |
| B1 | 8 |
| C | - |
| D | 28 |
| D1 | 24 |
| DM | 24 |
| DM1 | - |
| E | - |
| EA | - |
| EB | - |
| EC | - |
| F | - |
| FF | M8 |
| F1 | - |
| GG | 112.5 |
| G1 | - |
| G3 | 90 |
| H | - |
| H1 | 80 |
| H2 | - |
| I | 75 |
| K | - |
| KE | M8x16 |
| K0 | - |
| K1 | - |
| L | - |
| L1 | - |
| LB | - |
| LL | - |

ÖÖË ÒÁÒÔÏ ÒÏË

| | |
|-----|------|
| M | 115 |
| N | 95 |
| N1 | 57 |
| O | - |
| P | 130 |
| PM | 200 |
| PM1 | - |
| Q | - |
| R | 117 |
| R1 | - |
| S | - |
| S1 | - |
| T | 40 |
| TM | 27.3 |
| TM1 | - |
| TT | 31.3 |
| TT1 | 27 |
| V | - |
| W | 45° |

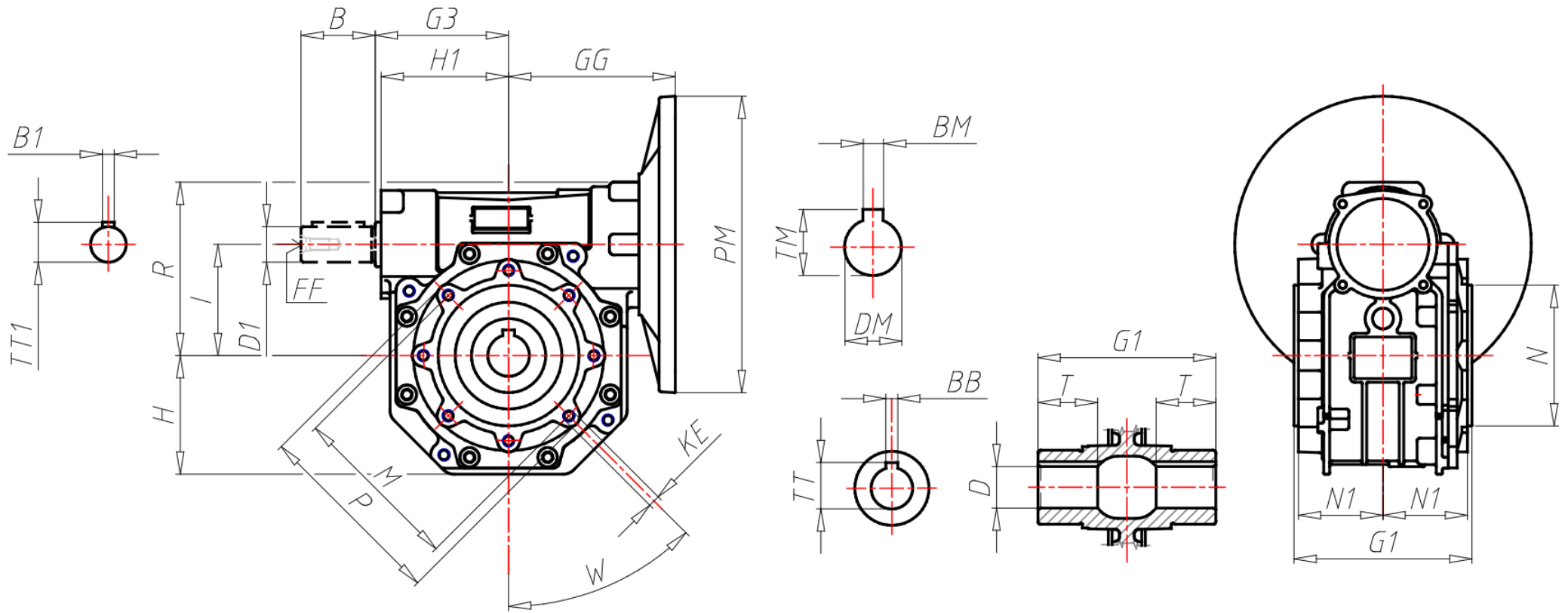

αεσôòùüœ

