

ç | È | Ì | Á | È | Ì | D | Ì | H | È | F | È | Ì | Á | È | æ | Å | ð | O | { | [| ç | æ | ã | È | ~

T U V U Ü Ö Ö W S V U Ü K N M R V - 0 6 3 / 1 5 0

{ | ç | ! | ^ | à | ~ | \ | ç | ! | Á | [| à , 5 | ð | ^ | Å | Ú | € | Ó | F | I | D

WIDOK 3D

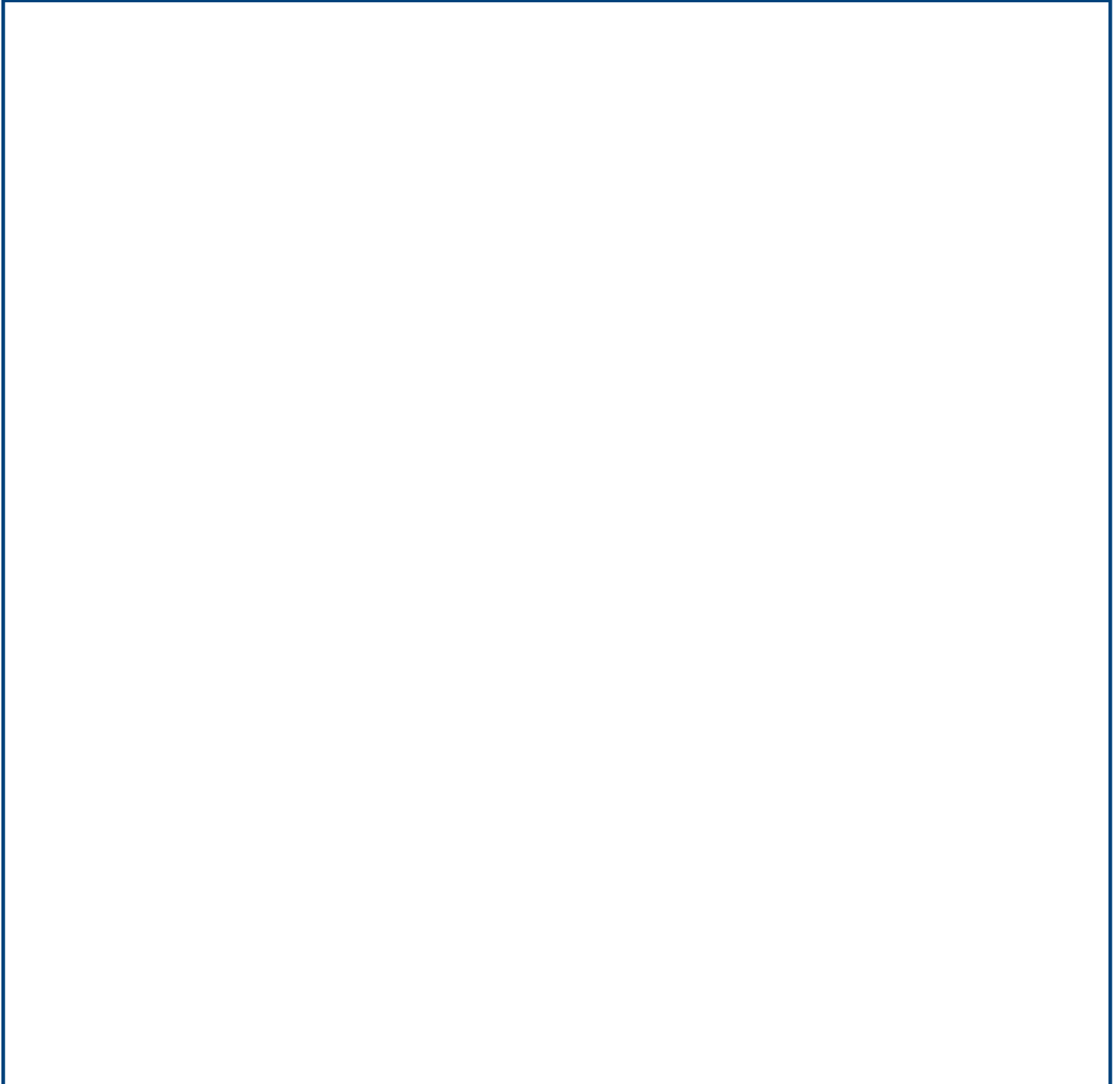

ÖÖË ÒÁÒÔÏ ÒÛÏ ÒÁÛ ÆÛÛ

GR Size	063-150
ES Execution	AS1
PAM Input PAM flange	90 B14
ACU1 Output hole shaft gear unit 1 (d)	25
VB1 Double input shaft gear unit 1	NO
ACU2 Output hole shaft gear unit 2 (d)	50
VB2 Double input shaft gear unit 2	NO
TFU Output flange gear unit 2	NO
DFU Output flange dimension gear unit 2 (d)	-
PFU Output flange position gear unit 2	-
AL2 Output hole shaft gear unit 2 (d)	NO
PAL Output shaft position gear unit 2	-
CAP Cover gear unit 2	NO
TIP Motor type	T-Three phase
GRA Motor size	090L
RAF Cooling	IC411-Self-Ventilated
FC Motor execution	B14
TF Break type	-
AF Brake power supply	-
COP Terminal box cover	Aluminium
CVE Fan cover	Default
MOR Terminal box cover position	1
A	144
AC	173
B	95
BB	14
BM	8
D	50
DM	24
E	50

F	M8x19
G1	200
H	170
H2	72
I	150
I2	63
L	323
LB	273
N2	53
PM	140
R	230
R2	102
T	72.5
TM	27
TT	53.8
Z	275

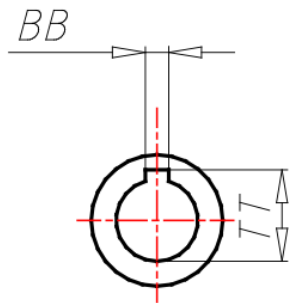
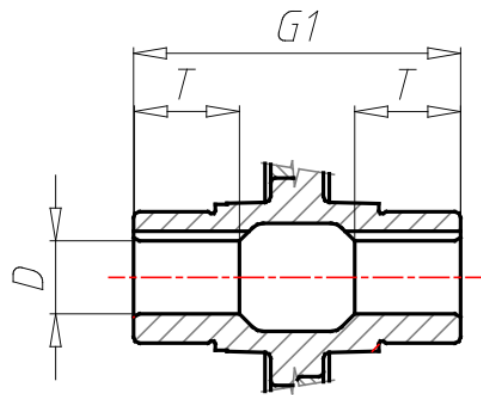
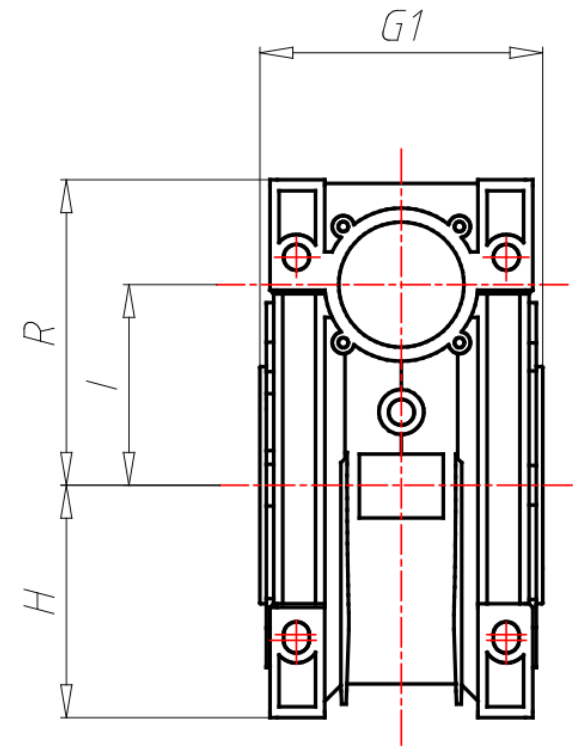
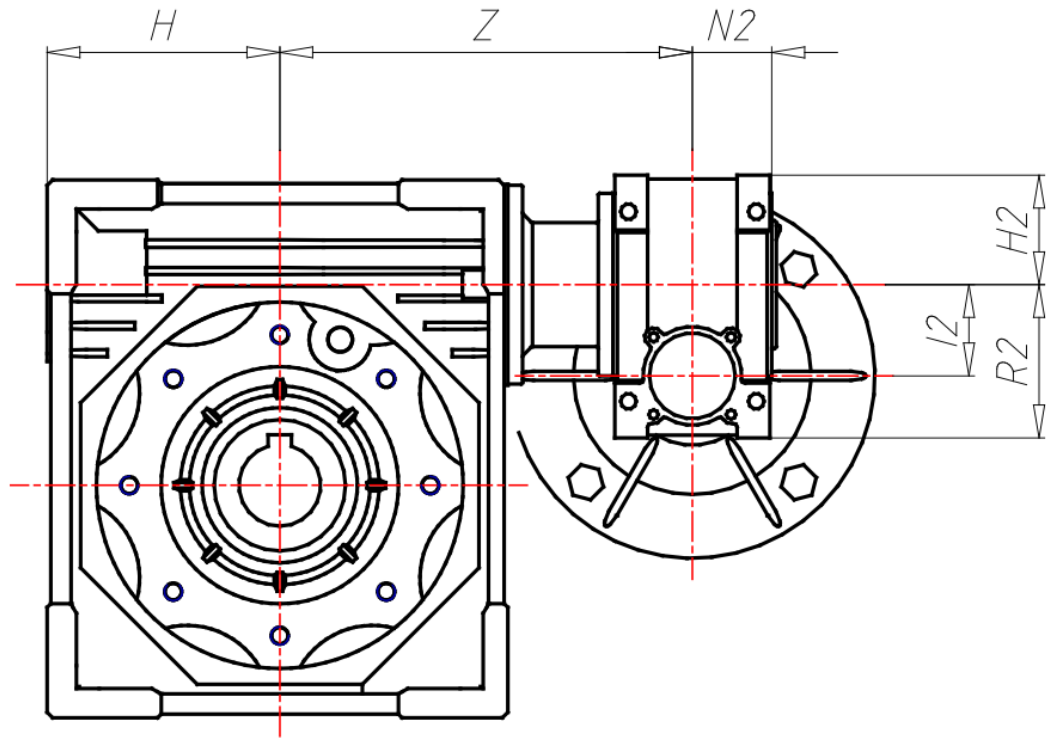
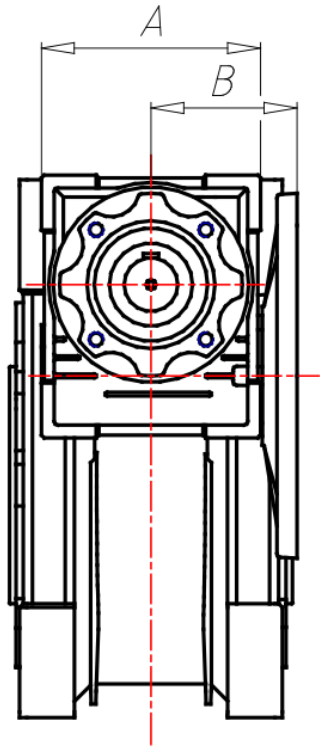

DESIGN

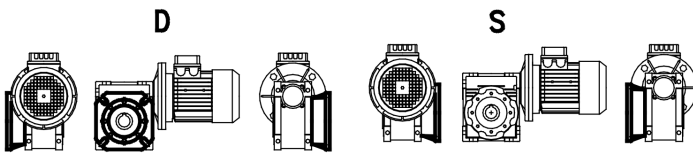
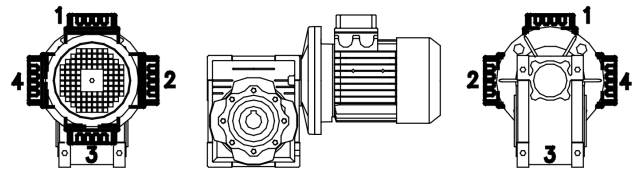
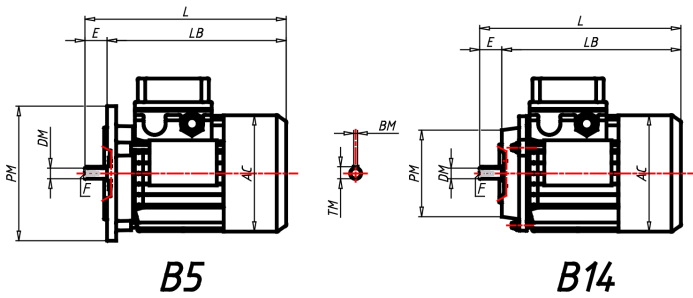

DESIGN

Ö [Á ^ * ~ | æ ß à | [ç , Á [ç | ^ á \ | ç | 5 , Á ç • ð Á ä Á ç | , } ä ä Ö ç ^ Á & @ & } ^ Á æ ß ç { æ Á Á ^ ! , ä æ ç & @ & } ^ & ç

@ ç | ç ^ á • ^ • ç { ç | ç

@ ç | ç ç | , } ä ç | ç

@ ç | ç ç | , } ä ç | ç { ç | ç

@ ç | ç ç | , } ä ç | ç ç | ç