

ç | È | Ì | Á | È | Ì | D | H | H | È | F | È | I | Á | È | æ | K | S | { | O | { | [| ç | æ | ã | È | ~

T UVUÜÒÖWSVUÜKNMRV-063/130

{ | ç | ! | ^ | à | ~ | \ | ç | ! | Á | [| à , 5 | b | ^ | Á | Ç | Ì | € | Ó | Í | D

WIDOK 3D

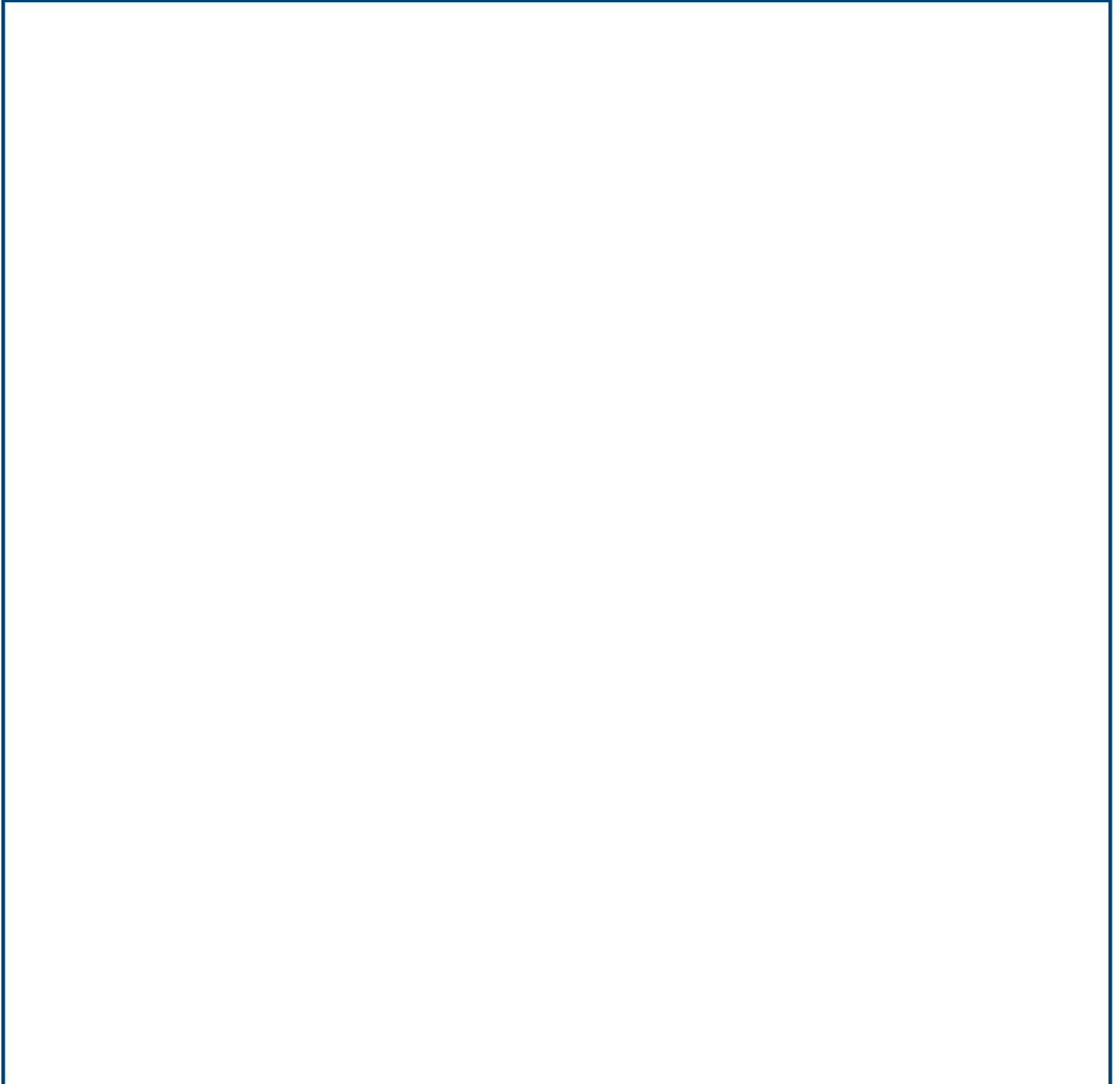

ÖÖË ÒÁÒÔÏ ÒÛÏ ÒÁÏ ÏÏÏ

GR Size	063-130
ES Execution	AS1
PAM Input PAM flange	80 B5
ACU1 Output hole shaft gear unit 1 (d)	25
VB1 Double input shaft gear unit 1	NO
ACU2 Output hole shaft gear unit 2 (d)	45
VB2 Double input shaft gear unit 2	NO
TFU Output flange gear unit 2	NO
DFU Output flange dimension gear unit 2 (d)	-
PFU Output flange position gear unit 2	-
AL2 Output hole shaft gear unit 2 (d)	NO
PAL Output shaft position gear unit 2	-
CAP Cover gear unit 2	NO
TIP Motor type	T-Three phase
GRA Motor size	080
RAF Cooling	IC411-Self-Ventilated
FC Motor execution	B5
TF Break type	-
AF Brake power supply	-
COP Terminal box cover	Aluminium
CVE Fan cover	Default
MOR Terminal box cover position	1
A	144
AC	158
B	95
BB	14
BM	6
D	45
DM	19
E	40

F	M6x16
G1	170
H	147.5
H2	72
I	130
I2	63
L	272.5
LB	232.5
N2	53
PM	200
R	187.5
R2	102
T	60
TM	21.5
TT	48.8
Z	245

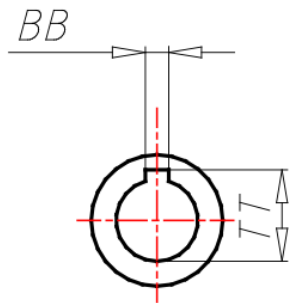
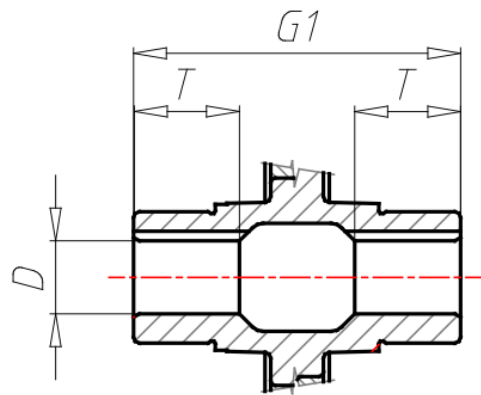
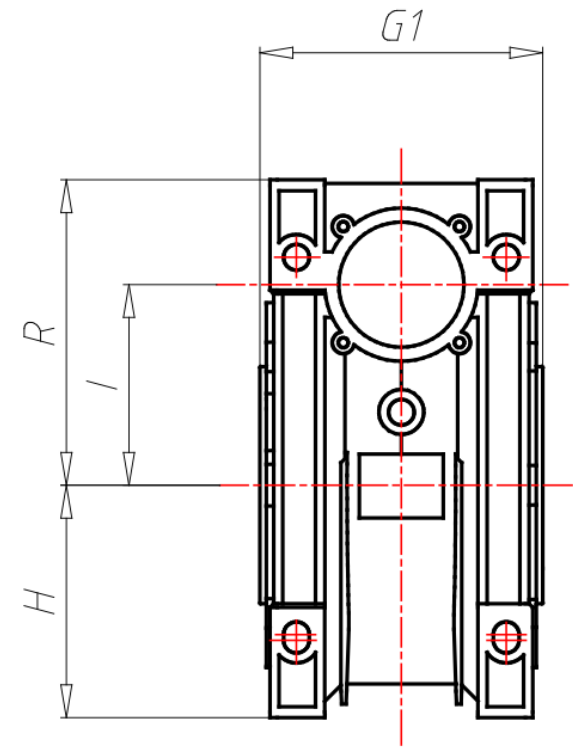
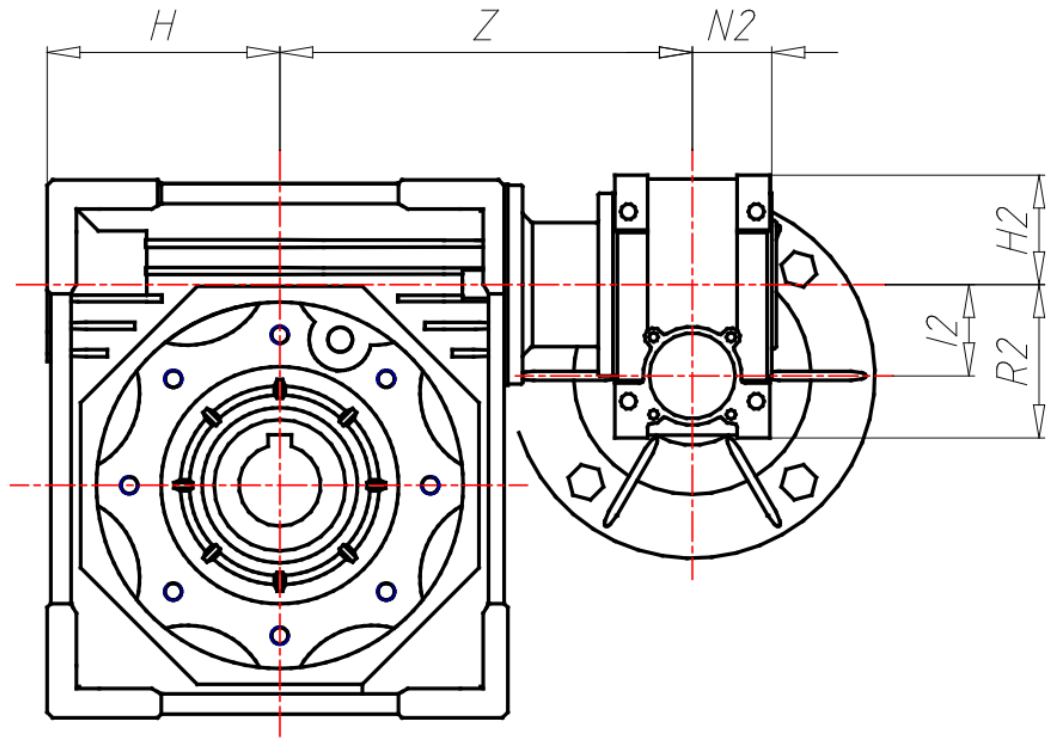
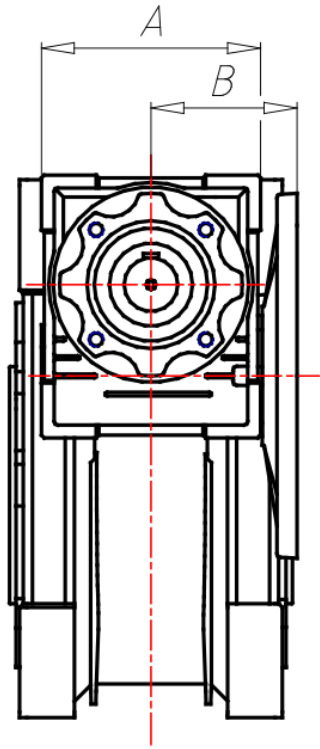

DESIGN

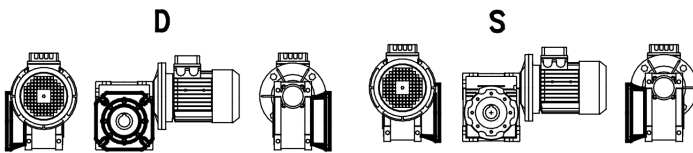
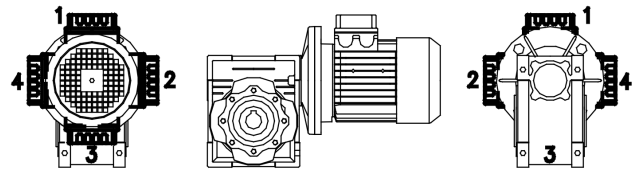
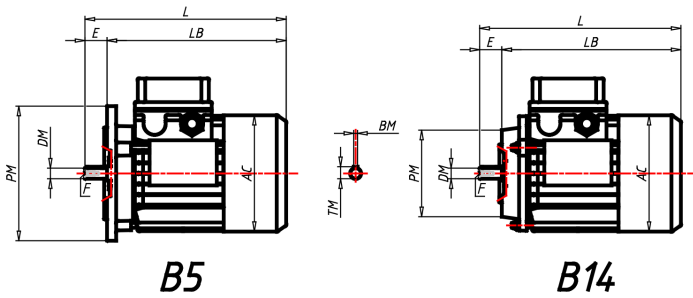

DESIGN

Ö [Á^*~ |æ&ñ ài[ç, Á [ç |^á\ ç |5, Á ç • ð Áã Áç, } ä äÖç ^Á & @ & } ^Á æ&ç { æ Á Á!, ä æ&ç & @ & } ^ & @

@ç KDeç, } ä æñ { ç |ð

@ç KDeç, } ä æñ { ç |ð

@ç KDeç, } ä æñ { ç |ð

@ç KDeç, } ä æñ { ç |ð