

ç | È | Ì | Á | È | Ì | D | H | È | F | È | I | Á | È | æ | K | ð | O | { | [| ç | æ | ã | È | ~

T UVUÜÒÖWSVUÜKNMRV-063/150

{ | ç | ! | ^ | à | ~ | \ | ç | ! | Á | [| à , 5 | b | ^ | Á | Ü | F | Ó | F | I | D

WIDOK 3D

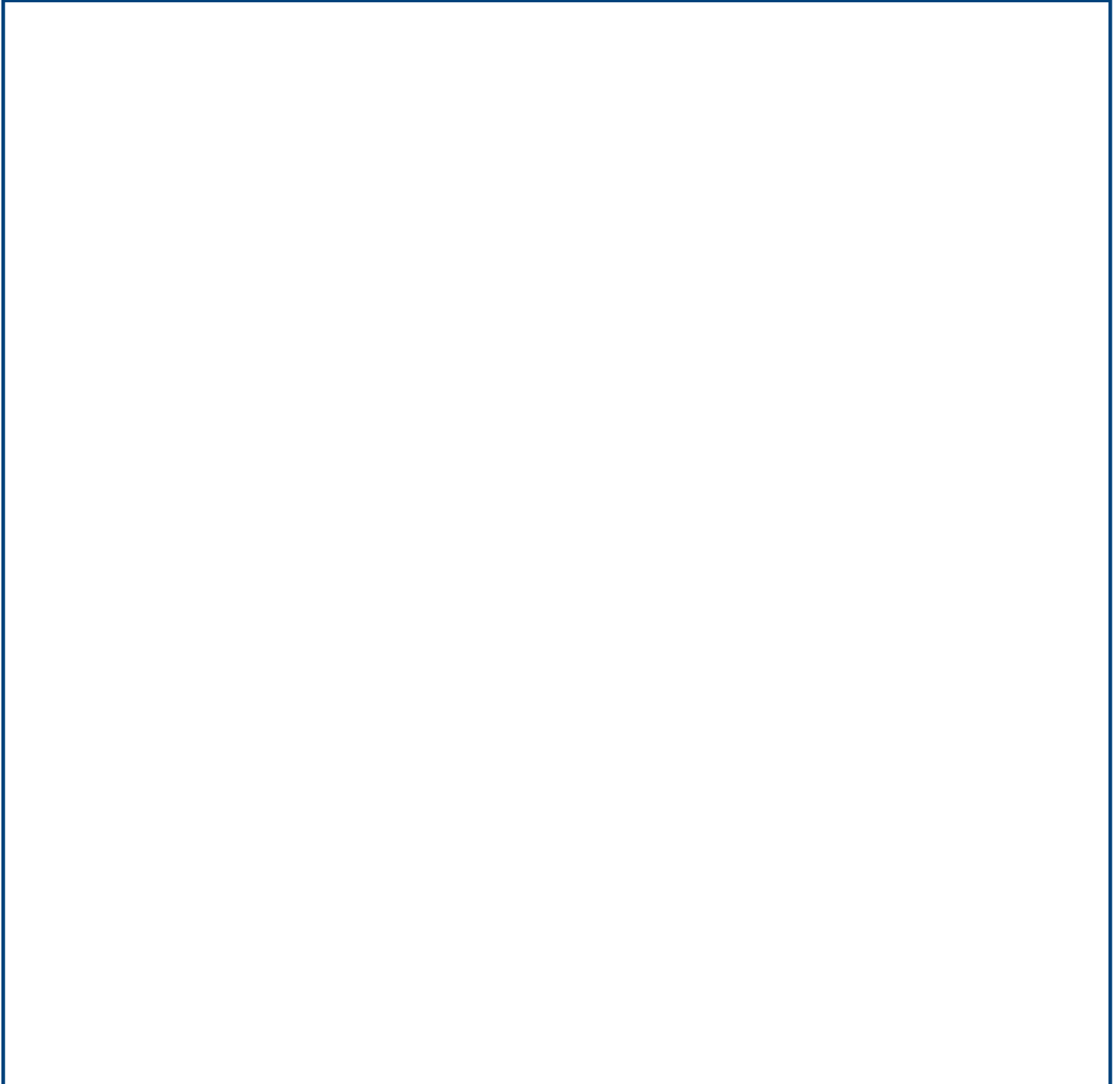

ÖÖË ÒÁÒÔÏ ÒÏÏ ÒÁÏ ÏÏÏ

| | |
|--|-----------------------|
| GR Size | 063-150 |
| ES Execution | AS1 |
| PAM Input PAM flange | 71 B14 |
| ACU1 Output hole shaft gear unit 1 (d) | 25 |
| VB1 Double input shaft gear unit 1 | NO |
| ACU2 Output hole shaft gear unit 2 (d) | 50 |
| VB2 Double input shaft gear unit 2 | NO |
| TFU Output flange gear unit 2 | NO |
| DFU Output flange dimension gear unit 2 (d) | - |
| PFU Output flange position gear unit 2 | - |
| AL2 Output hole shaft gear unit 2 (d) | NO |
| PAL Output shaft position gear unit 2 | - |
| CAP Cover gear unit 2 | NO |
| TIP Motor type | T-Three phase |
| GRA Motor size | 071 |
| RAF Cooling | IC411-Self-Ventilated |
| FC Motor execution | B14 |
| TF Break type | - |
| AF Brake power supply | - |
| COP Terminal box cover | Aluminium |
| CVE Fan cover | Default |
| MOR Terminal box cover position | 1 |
| A | 144 |
| AC | 139 |
| B | 95 |
| BB | 14 |
| BM | 5 |
| D | 50 |
| DM | 14 |
| E | 30 |

| | |
|-----------|----------------|
| F | M5x12.5 |
| G1 | 200 |
| H | 170 |
| H2 | 72 |
| I | 150 |
| I2 | 63 |
| L | 238.5 |
| LB | 208.5 |
| N2 | 53 |
| PM | 105 |
| R | 230 |
| R2 | 102 |
| T | 72.5 |
| TM | 16 |
| TT | 53.8 |
| Z | 275 |

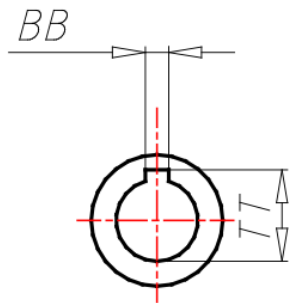
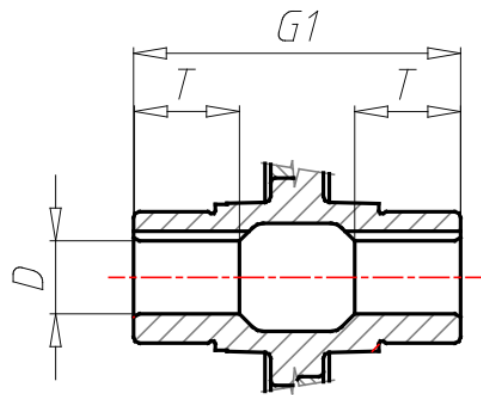
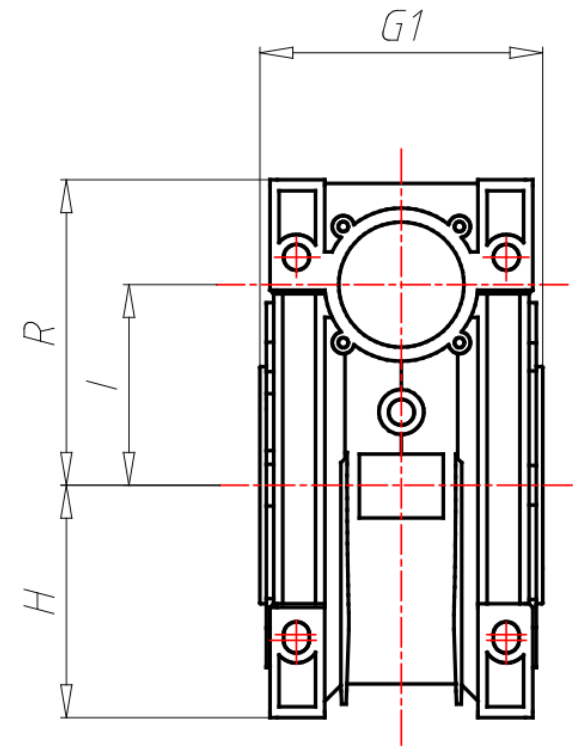
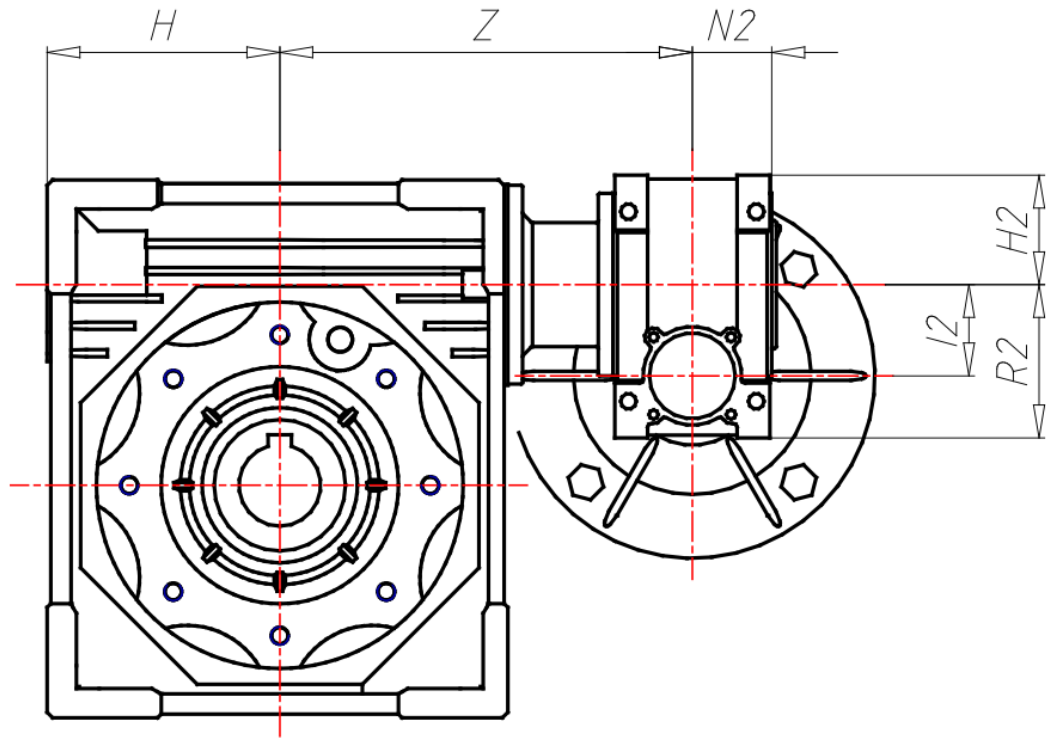
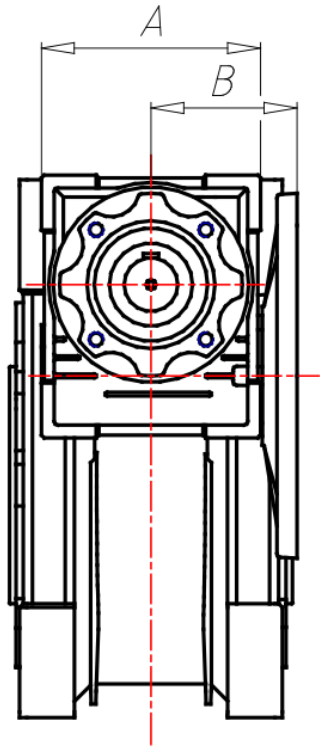

DESIGN

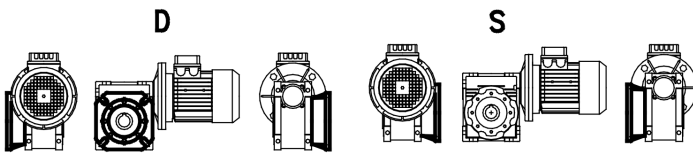
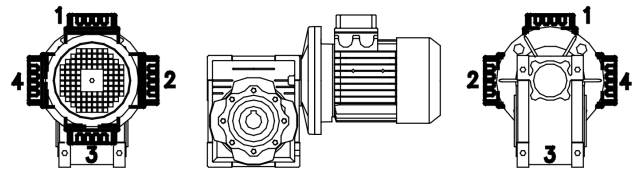
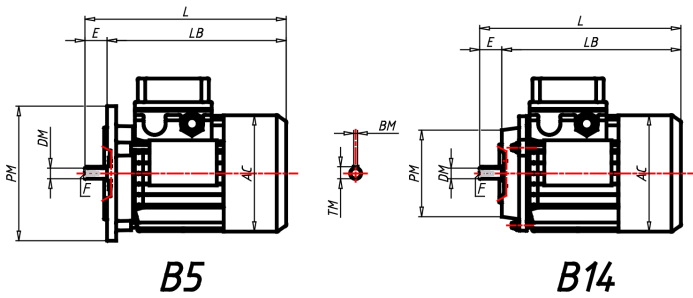

DESIGN

Ö [Á ^ * ~ | æ ß à i [ç , Á [ç | ^ á \ ç i 5 , Á ç • ð Á ä Á ç | , } ä ä Ö ç ^ Á & @ & } ^ Á æ ß ç { æ Á Á ! , ä æ ç & @ & } ^ & ç

@ ç | ç ^ à • ^ • ç { ç | ç

@ ç | ç ç | , } ä ç | ç

@ ç | ç ç | , } ä ç | ç { ç | ç

@ ç | ç ç | , } ä ç | ç ç | ç