

ç | È | Ì | Á | È | Ì | D | Ì | H | È | F | È | Ì | Á | È | æ | Å | Æ | Æ | Ö | { | [| ç | æ | ã | È | ~

T U V U Ü Ö Ö W S V U Ü K N M R V - 0 3 0 / 0 5 0

{ | ç | ! | ^ | à | ~ | \ | ç | ! | Á | [| à | , | 5 | b | ^ | Á | Ç | Í | Î | Ó | F | I | D

WIDOK 3D

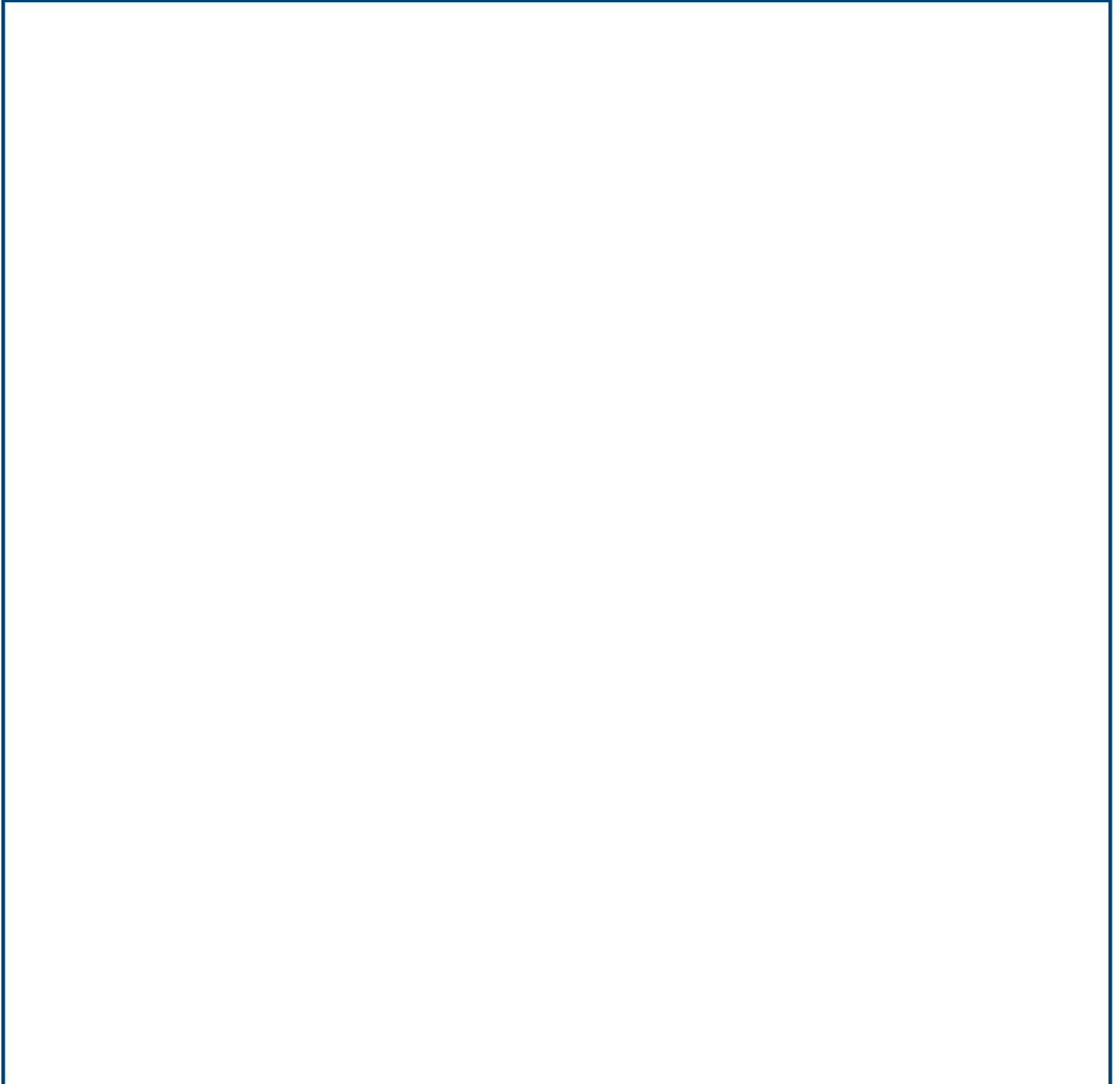

ÖÖË ÒÁÒÔÏ ÒÏÏ ÒÁÏ ÏÏÏ

GR Size	030-050
ES Execution	AS1
PAM Input PAM flange	56 B14
ACU1 Output hole shaft gear unit 1 (d)	14
VB1 Double input shaft gear unit 1	NO
ACU2 Output hole shaft gear unit 2 (d)	25
VB2 Double input shaft gear unit 2	NO
TFU Output flange gear unit 2	NO
DFU Output flange dimension gear unit 2 (d)	-
PFU Output flange position gear unit 2	-
AL2 Output hole shaft gear unit 2 (d)	NO
PAL Output shaft position gear unit 2	-
CAP Cover gear unit 2	NO
TIP Motor type	T-Three phase
GRA Motor size	056
RAF Cooling	IC411-Self-Ventilated
FC Motor execution	B14
TF Break type	-
AF Brake power supply	-
COP Terminal box cover	Aluminium
CVE Fan cover	Default
MOR Terminal box cover position	1
A	80
AC	-
B	55
BB	8
BM	-
D	25
DM	-
E	-

F	-
G1	92
H	60
H2	40
I	50
I2	30
L	-
LB	-
N2	29
PM	80
R	84
R2	57
T	30
TM	-
TT	28.3
Z	132

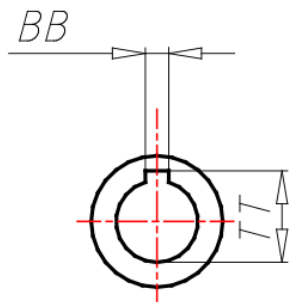
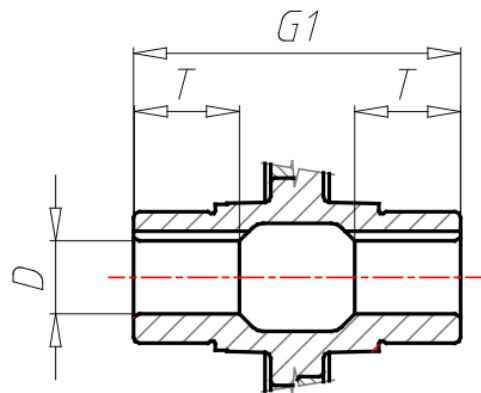
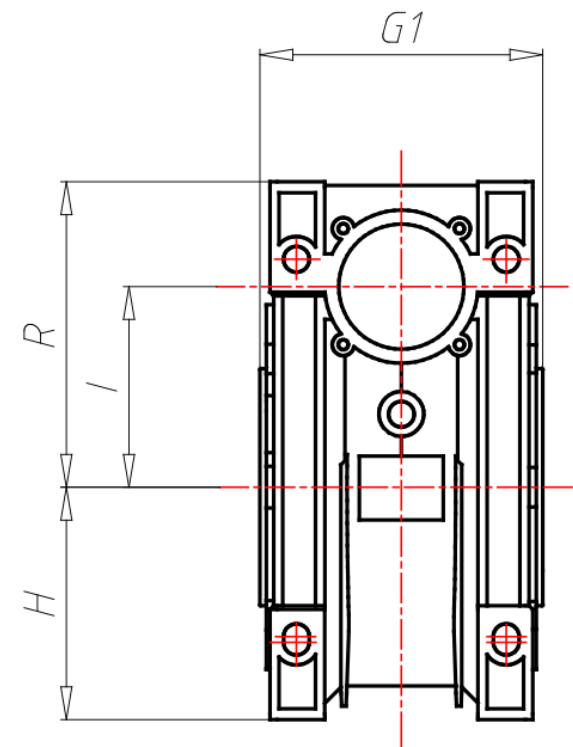
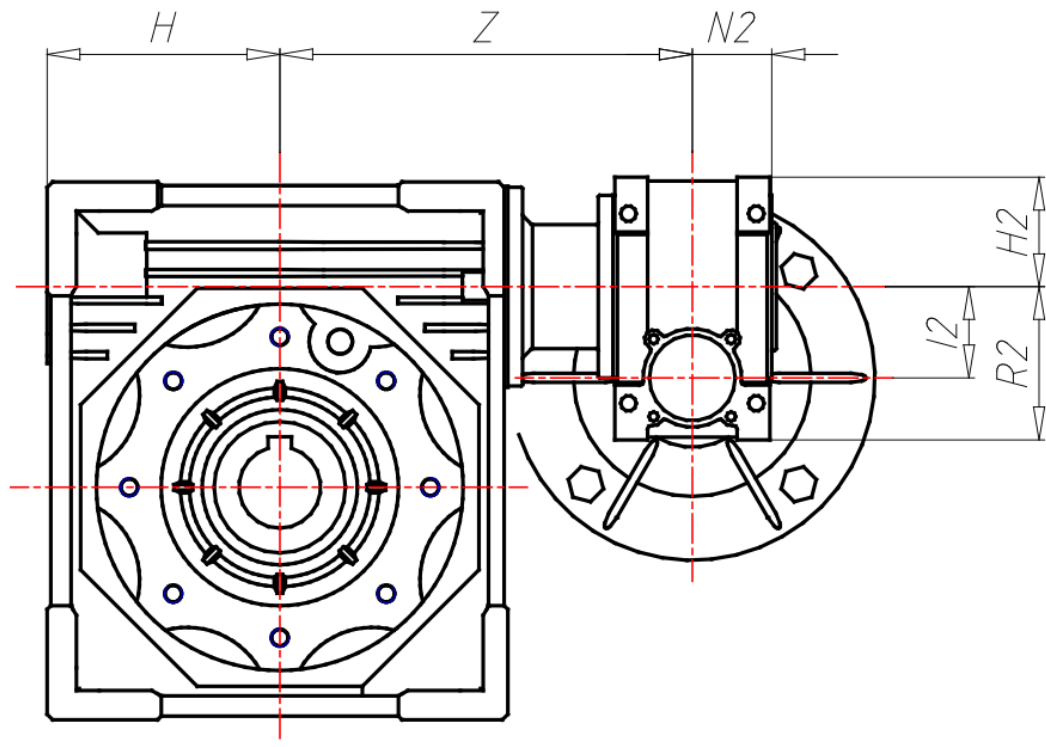
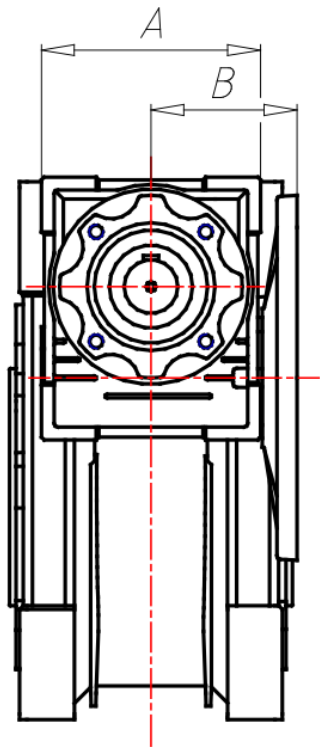

DESIGN

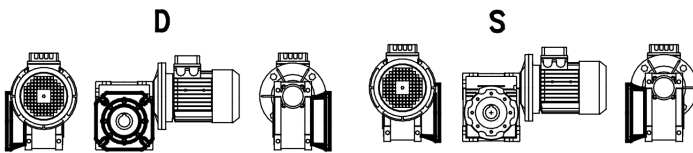
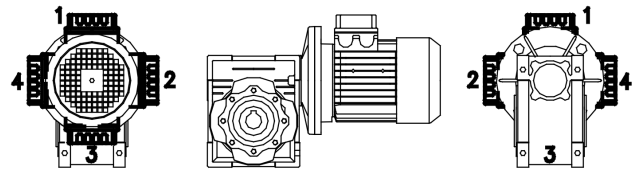
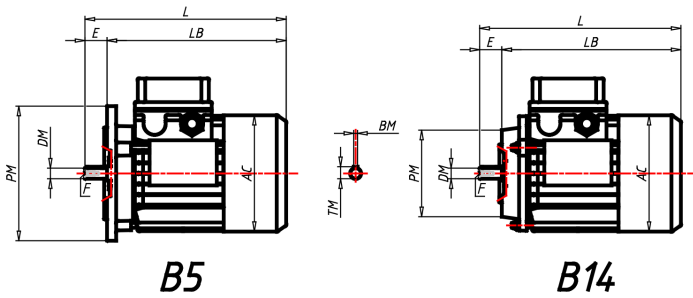

DESIGN

Ö [Á^*~ |æ&ñ ài[ç, Á [ç |^á\ ç |5, Á ç • ð Áã Áç, } ä äÖç ^Á & @ & } ^Á æ&ç { æÁ Á^!, ä æ&ç & @ & } ^ & @

@ç KDeç, } ä æñ { ç |ð

@ç KDeç, } ä æñ { ç |ð

@ç KDeç, } ä æñ { ç |ð

@ç KDeç, } ä æñ { ç |ð