

ç|ÈI Ì ÁÈ Ì DÌ HÈ FÈ I ÁÈ æIKO { O { [d çæã È~

T UVUÜÒÖWSVUÜKNMRV-025/040

{ [d !^ã~ \ d !Á [å, 5b ^ ÁÚÍ Î ÓFI D

WIDOK 3D

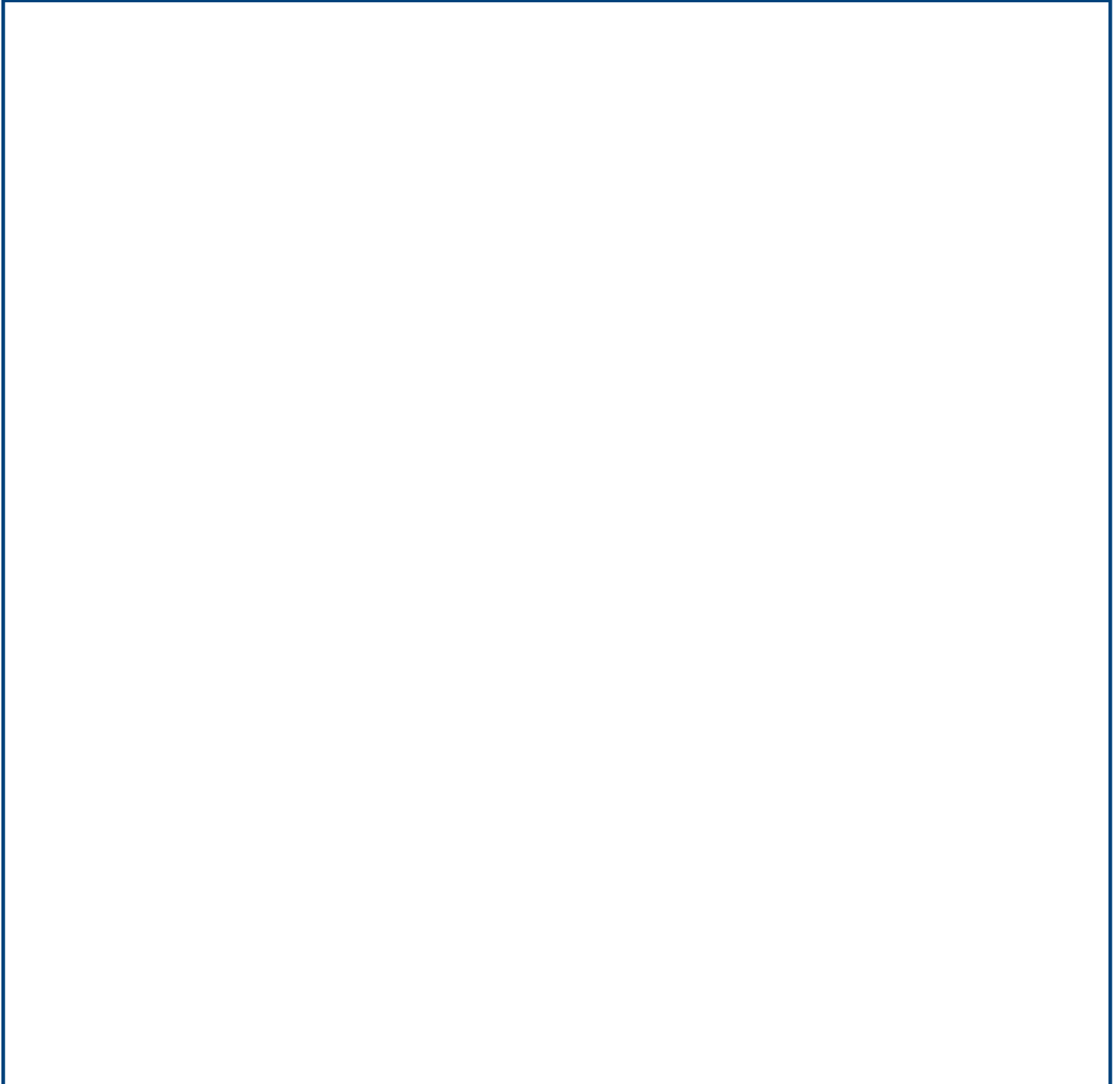

ÖÖË ÒÁ/ÒÔP ÒÔZ ÒÁÁ ÝT ÖËÿ

GR Size	025-040
ES Execution	AS1
PAM Input PAM flange	56 B14
ACU1 Output hole shaft gear unit 1 (d)	11
VB1 Double input shaft gear unit 1	NO
ACU2 Output hole shaft gear unit 2 (d)	18
VB2 Double input shaft gear unit 2	NO
TFU Output flange gear unit 2	NO
DFU Output flange dimension gear unit 2 (d)	-
PFU Output flange position gear unit 2	-
AL2 Output hole shaft gear unit 2 (d)	NO
PAL Output shaft position gear unit 2	-
CAP Cover gear unit 2	NO
TIP Motor type	T-Three phase
GRA Motor size	056
RAF Cooling	IC411-Self-Ventilated
FC Motor execution	B14
TF Break type	-
AF Brake power supply	-
COP Terminal box cover	Aluminium
CVE Fan cover	Default
MOR Terminal box cover position	1
A	70
AC	-
B	45
BB	6
BM	-
D	18
DM	-
E	-

PRODUCT DRAWING RELEASE

Last Modification (geometry): 27/06/2014 10:03

Datasheet creation date: 05/08/2015 13:11

F	-
G1	78
H	50
H2	35
I	40
I2	25
L	-
LB	-
N2	22.5
PM	80
R	71.5
R2	48
T	26
TM	-
TT	20.8
Z	115

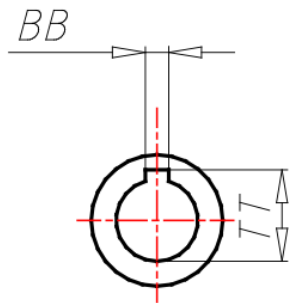
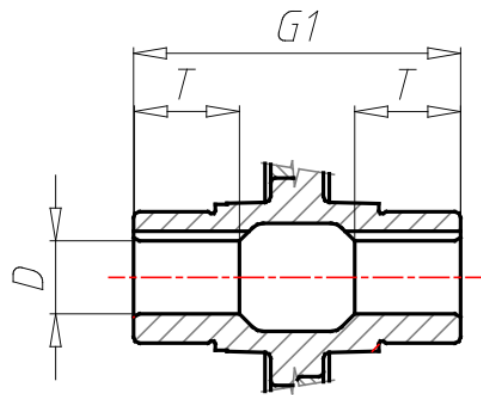
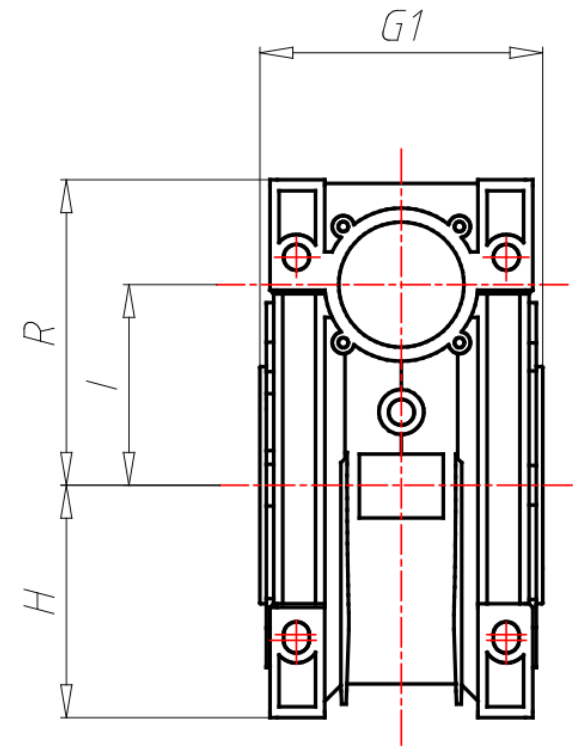
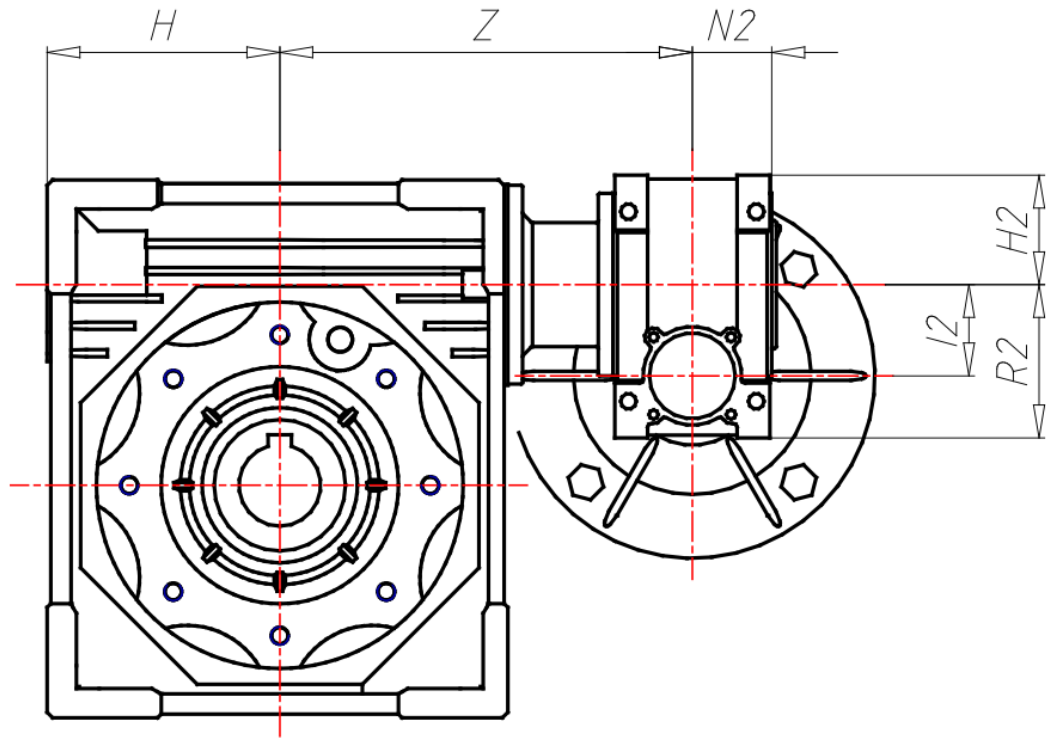
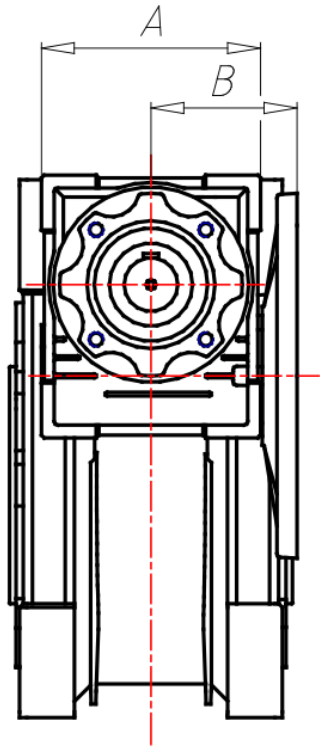

DESIGN

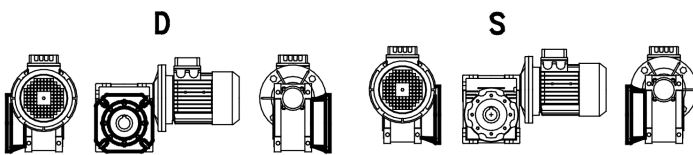
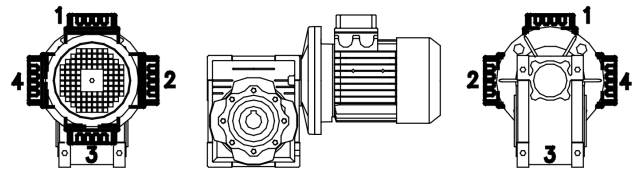
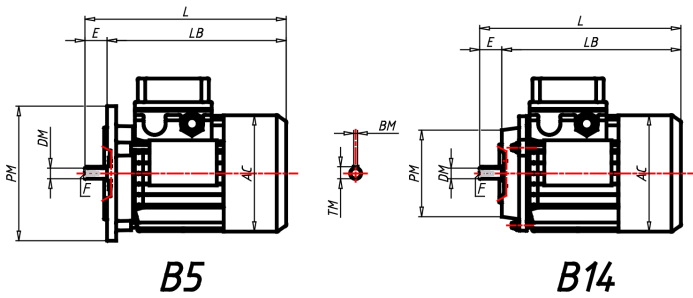

DESIGN

Ö [Á ^ ~ | a a a | c , Á [d | ^ a ~ \ d ! 5 , Á y Á a , } a a a | { a a Á & @ & } ^ Á a a a { a a Á ^ ! , a a a @

@ d K D a ^ • c { E |

@ d K D a , } a a E |

@ d K D a , } a a { E |

@ d K D a , } a a E |